

# MK1033CW-1



## Specifications

Capacity	Maximum	0.995t x 1.3m
Working radius	Maximum	9.9m x 180kg
Lifting height	Maximum	11.3m x 605kg
Weight and dimensions	Diesel only	2290kg, 2900mm x 750mm x 1955mm
	With winch	2390kg, 3030mm x 750mm x 1990mm
	With diesel / electric motor	2270kg, 3235mm x 750mm x 1955mm
	With winch and electric motor	2370kg, 3235mm x 750mm x 1990mm
Hook speed (optional)	Maximum	37.8 m / min (5th layer, single fall)
Hoist rope (optional)	Type	IWRC 6 X WS (26) 8mm x 73m
Main boom telescopic system	Boom length	2.590m - 6.030m
	Telescoping speed Boom type	3.44m / 15.5sec [0.22m/sec] Fully automatic 3-section pentagonal telescopic boom (2 and 3 section: simultaneous telescoping)
	Hoist angle / speed	0 to 80° / 36.4sec
Jib telescopic system	Jib length	1.876m - 4.111m
	Telescoping speed Jib type	2.235m / 22.4sec [0.10m/sec] Fully automatic 3-section pentagonal telescopic jib
	Hoist angle / speed	-100 to 80° / 26.4sec
Slew system	Slew angle / speed	360° / 0.86rpm
Outrigger system	Type	1st stage with flexible stay damper, 2nd stage manual pullout hydraulic cylinder direct acting type.
	Maximum outriggers	Length 4580mm x Front 4530mm x Rear 3810mm
Traction system	Drive	Hydraulic motor driven, stepless speed changer
	Travel speed	0 - 2.0km / h
	Gradability	15°
	Ground length x width	975mm x 200mm (Track dimensions)
	Ground pressure - with motor and winch	0.54kgf/cm <sup>2</sup> 0.61kgf/cm <sup>2</sup>
Engine	Model	Yanmar 2TNV70-NMBA
	Type	2 cylinder water cooled diesel
	Rated output	7.4 kW / 2500 rpm
	Starting method	Electric
	Fuel tank capacity	Diesel / 12L
Self-detachable electric motor (optional)	Type Size	Fully enclosed fan cooled motor 5.5 kW 4P 380V
Standard equipment	Level, Machine body inclination alarm, EMO switch, Hydraulic safety valves, Overwind protection, Wire rope latch, Crane/Outrigger interlock device, Moment limiter, Data logger, Slew restriction device, HBC radio remote control.	
Optional equipment	820kg Winch (single fall) Self-detachable Electric Motor White rubber tracks	



Auxiliary Winch (Optional)



Self-detachable Electric Motor (Optional)



# Mini Crane Knuckle Boom

# MK1033C



[www.kranlyft.com](http://www.kranlyft.com)

[www.kranlyft.com](http://www.kranlyft.com)

The new MK1033 is unique in the range being a knuckleboom crane. It is a narrow aisle, operator-controlled crane with the advantage of a hydraulic 6-section luffing boom and jib. This gives the crane a serious "up and over" capacity, making it easier to perform many tasks such as glass handling and installation, lifting in narrow spaces and placing Dormers and Velux units on rooftops. The MK1033 is still narrow enough to fit through a standard doorway yet boasts a lifting capacity of 0.995t and a lifting height of 11.3m.

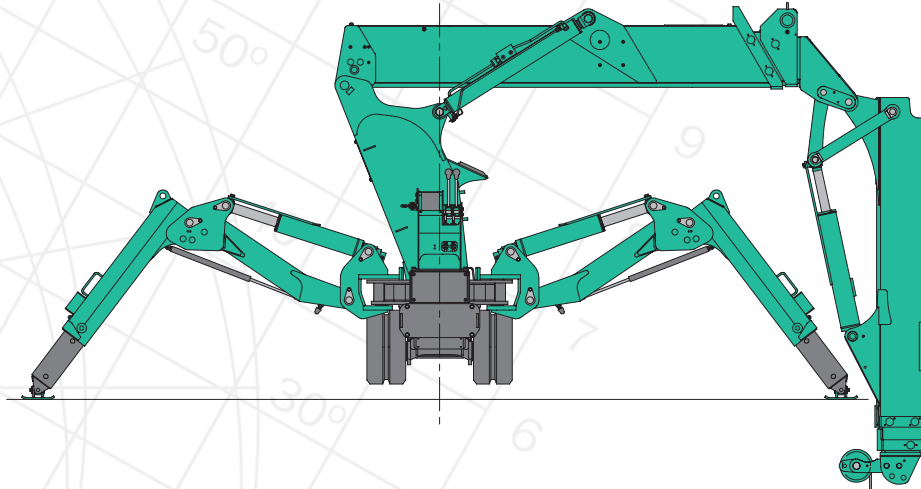

- 0.995 Ton Max Capacity
- 11.3m Max Working Height
- Super Slim Body Width (750mm)
- HBC Radio Remote Control
- Outrigger Interlock System
- Low Ground Pressure
- Manoeuvrability & Stability
- New display and Moment Limiter
- Multi Outrigger positions
- Slew Restriction Device
- Optional Self-detachable Electric Motor
- Hydrostatic Transmission
- Tilt Alarm
- Radio Remote Control System
- Optional 820 kg Winch with Hydraulic Disc Brake
- Data Logger
- 2 Year Warranty

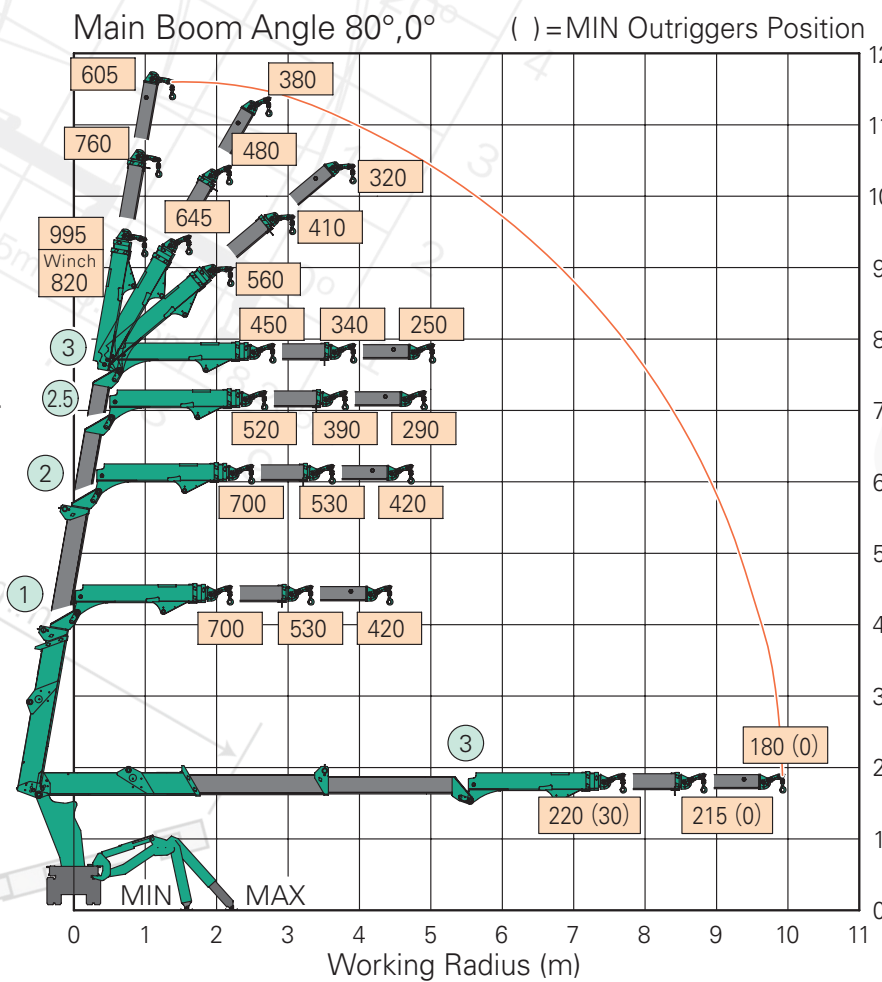

Single Fall  
66.5m

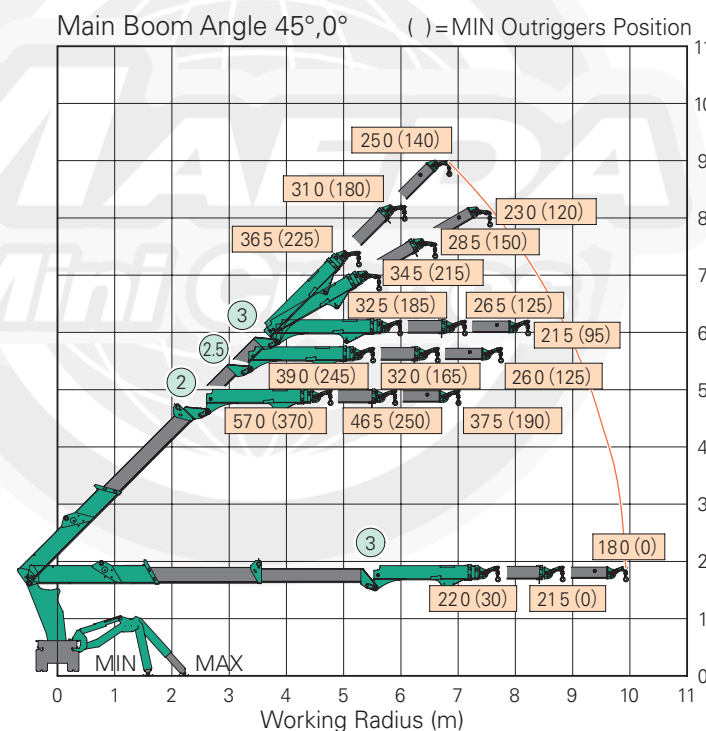
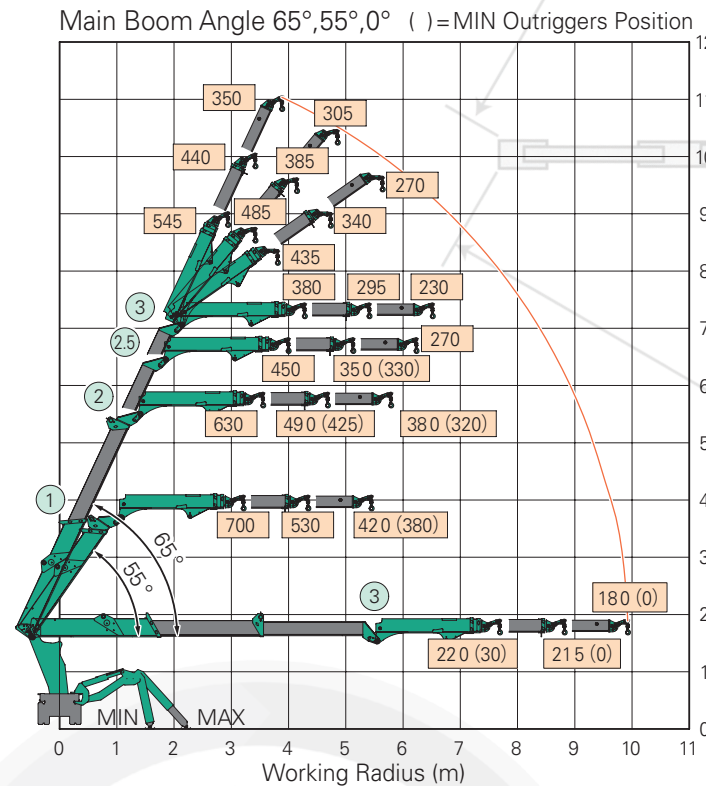

**Outrigger Footprints**

Diagram shows outriggers at maximum and minimum position.

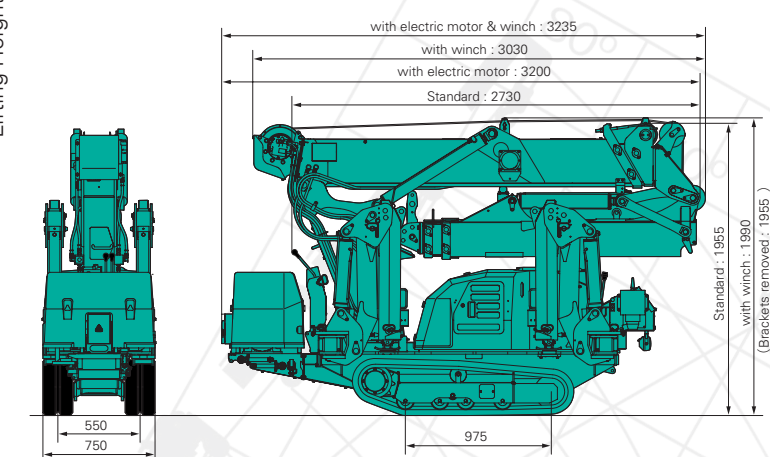
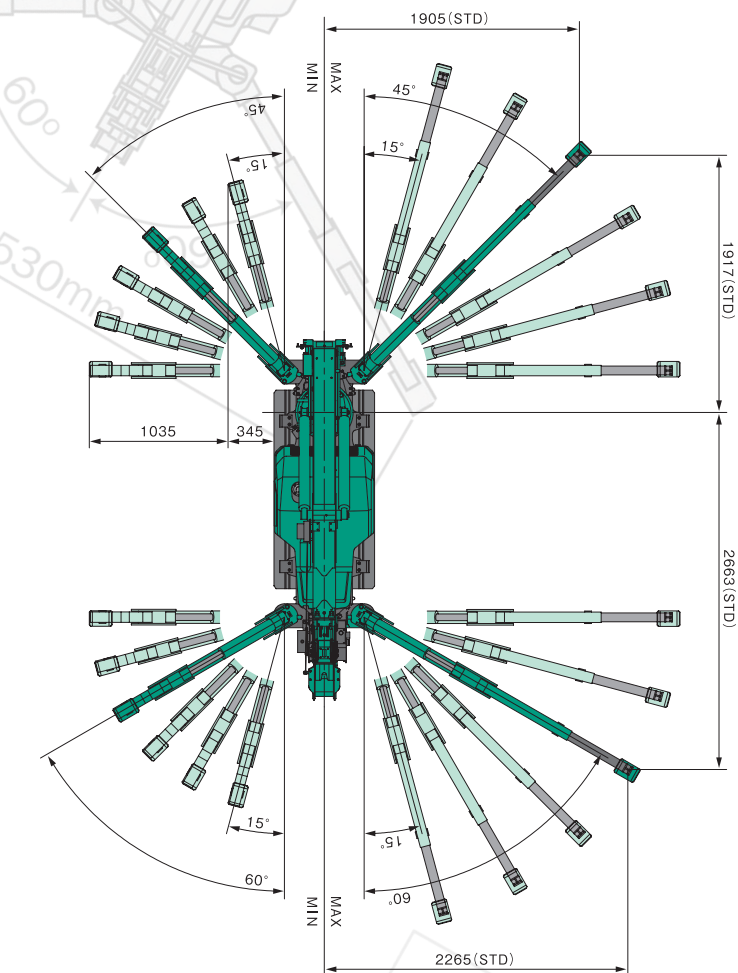

The values in    are rated total load (kg), they are based on the actual working radius including boom & jib deflection.