

GMK4080-3

Product Guide



 80 t

 51 m

 8,7 - 21,0 m

 75 m

GROVE GMK4080-3

Compact and strong.

Kompakt und stark.

Compact et fort.

Compacto y fuerte.

Compatto e forte.

Компактный и сильный.



Features

- The minimum width of the GMK4080-3 is 2,55 m and the overall length is 12,68 m.
Die Fahrzeugbreite des GMK4080-3 beträgt 2,55 m und die Gesamtlänge 12,68 m.
La largeur minimale de la GMK4080-3 est de 2,55 m et sa longueur totale est de 12,68 m.
La anchura mínima de la GMK4080-3 es de 2,55 m y la longitud global es de 12,68 m.
La larghezza minima della GMK4080-3 è di 2,55 m e la lunghezza totale è di 12,68 m.
Минимальная ширина GMK4080-3: 2,55 м Габаритная длина: 12,68 м.

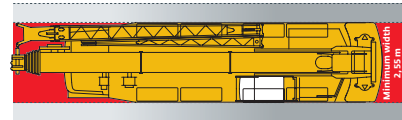

- MAXbase variable outrigger positioning for increased capacities and flexibility on jobsites.
MAXbase - mit der variablen Abstützung steigern Sie Traglast und Flexibilität am Einsatzort.

MAXBase: Positionnement variable des stabilisateurs pour accroître les capacités de levage et la flexibilité sur les chantiers.

El sistema MAXbase de apertura variable de los estabilizadores aporta mayor capacidad y flexibilidad en el lugar de trabajo.

Stabilizzazione variabile MAXbase per maggiori capacità di sollevamento e flessibilità in cantiere.

MAXbase система с адаптивно-изменяемым расположением аутригеров для обеспечения наибольшей грузоподъемности и маневренности на любой площадке!

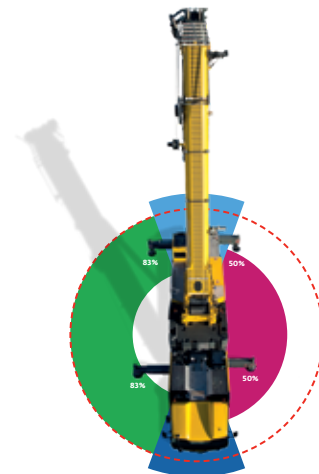

- The new single engine concept on the GMK4080-3 with the latest EUROMOT 5/Tier 4 final engine reduces fuel consumption to a minimum. Using the ECO mode, the GMK4080-3 is the most fuel efficient crane in its class.

Das neue Einmotorenkonzept des GMK4080-3, mit modernster Euromot 5/Tier 4 final Motortechnologie verringert den Kraftstoffverbrauch auf ein Minimum. Durch den ECO-Mode erreicht der GMK4080-3 den geringsten Verbrauch in seiner Klasse.

Le nouveau concept de monomoteur sur la GMK4080-3 avec le dernier EUROMOT 5/Tier 4 final réduit au minimum la consommation en carburant du moteur. Grâce au mode ECO, la GMK4080-3 est la grue la plus économe en carburant de sa catégorie.

El nuevo concepto de motor único de la GMK4080-3 con el último motor EUROMOT 5/Tier 4 Final reduce al mínimo el consumo de combustible. Utilizando el modo ECO, la GMK4080-3 es la grúa que menos combustible consume de su clase.

Il nuovo concetto a motore singolo sulla GMK4080-3 con il nuovissimo motore EURO-MOT 5/Tier 4 final riduce il consumo di carburante al minimo. Usando la modalità ECO, la GMK4080-3 è la gru con il più basso consumo di carburante della sua classe.

Новая одномоторная концепция: Дизельный двигатель автокрана GMK4080-3, соответствующий экологическому классу EUROMOT 5/Tier 4/Евро 6, расход топлива сведен минимуму. В режиме ECO автокран GMK4080-3 обеспечивает самую высокую топливную экономичность в своем классе.



Jobsite benefits

- Access narrow jobsites and utilize a more compact radius to gain a better position for lift performance. Compact size provides excellent jobsite flexibility.

Sie erreichen schwer zugängliche Baustellen, können den Kran auch auf engstem Raum positionieren und dadurch optimale Hubleistungen erreichen. Die kompakten Abmaße bieten mehr Flexibilität auf der Baustelle.

Elle permet d'accéder à des chantiers étroits et utilise un rayon plus compact pour obtenir une position offrant une meilleure performance de levage. Sa taille compacte procure une excellente flexibilité sur le chantier.

Puede acceder a espacios estrechos y utiliza un radio más reducido para obtener una mejor posición y ofrecer mejor rendimiento de elevación. Gracias a su tamaño reducido, ofrece mayor flexibilidad en el espacio de trabajo.

Può accedere a strette aree di lavoro e utilizza un raggio compatto per ottenere una migliore posizione per le operazioni di sollevamento. Le dimensioni compatte forniscono un'ottima flessibilità sull'area di lavoro.

Подходит для работы в стесненных условиях, отличается малым радиусом разворота, что позволяет выбрать оптимальное положение крана на площадке, с точки зрения грузовысотных характеристик. Компактные размеры – обеспечивают высокую эксплуатацию гибкость.

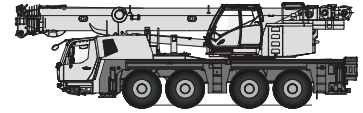

- Taxi counterweight offers the best load charts in its class outfitted with 10,2 t counterweight on 12 t/axle. The remaining counterweight needed to reach full capacity fits on one standard trailer.

Mit 10,2 t Gegengewicht in der Taxikonfiguration bietet der GMK4080-3 die besten Traglasten seiner Klasse. Das verbleibende Gegengewicht lässt sich auf nur einem Standardanhänger transportieren.

Le contrepoids «taxi» offre les meilleures capacités de levage de sa catégorie, équipé avec un contrepoids de 10,2 t avec 12 t/essieu. Le contrepoids restant requis pour atteindre la pleine capacité s'adapte à une remorque standard.

El contrapeso taxi ofrece los mejores gráficos de cargas de su clase equipado con un contrapeso de 10,2 t con 12 t/eje. El contrapeso requerido restante para alcanzar su capacidad total se ajusta a un remolque estándar.

La zavorra tipo «taxi» offre i migliori diagrammi di carico della sua classe, equipaggiata con una zavorra di 10,2 t su un asse da 12 t. La rimanente zavorra necessaria per raggiungere la piena capacità è collocata su un rimorchio standard.

Противовес, из нескольких секций, обеспечивает лучшие параметры грузоподъемности в своем классе. Автокран оснащен противовесом «Такси» 10,2 т в конфигурации 12 т/ось. Остальные секции противовеса, необходимые для достижения максимальной грузоподъемности, вмещаюся в один стандартный полуприцеп.

Manitowoc Crane Care™

The assurance of the world's most advanced crane service and support to get you back to work fast.

Manitowoc Crane Care vereint alle Serviceleistungen von Manitowoc im Produktsupport vor und nach dem Kauf: Ersatzteile, Service, technische Dokumentation, technischer Support und Schulung, alles aus einer Hand.

L'assurance de temps morts réduits grâce à la meilleure qualité de service et d'assistance pour grues au monde.

La seguridad de contar con el más avanzado servicio técnico y soporte de grúa para ayudarlo a volver rápido al trabajo.

La garanzia dell'assistenza e della manutenzione per gru più avanzate del mondo per riprendere velocemente il lavoro.

Гарантия лучшего в мире обслуживания кранового оборудования и техподдержки, для максимального быстрого восстановления работоспособности.

Manitowoc Finance™

Financial tools that help you capitalize on opportunity with solutions that fit your needs.

Individuelle Finanzierungslösungen, mit unseren Kooperationspartnern entwickelt, um Ihre bereits bestehenden Finanzierungsstrukturen zu ergänzen.

Des outils financiers qui vous aident à investir à bon escient grâce à des solutions adaptées à vos besoins.

Herramientas financieras que le ayudan a sacar provecho de las oportunidades, con soluciones que se ajustan a sus necesidades.

Strumenti finanziari che consentono di capitalizzare le opportunità con soluzioni che si adattano alle vostre esigenze.

Финансовые инструменты, позволяющие вам развивать бизнес, опираясь на решения, отвечающие вашим потребностям.

Contents • Inhalt • Contenu Contenido • Contenuto • Содержание

| | |
|--|-----------|
| Dimensions • Abmessungen • Encombremet • Dimensiones • Dimensioni • Размеры | 5 |
| Counterweight • Gegengewicht • Contrepoids • Contrapesos • Contrappesi • Противовес | 6 |
| Data • Daten • Caractéristiques • Datos • Dati • Данные | 7 |
| Load charts • Traglasten • Capacités de levage • Capacidades • Capacità • Таблицы грузоподъемности | |
| Jib configurations • Kombination der Auslegerverlängerung • Combinaisons de l'extension treillis • Configuración con extensiones de pluma • Combinazioni delle prolunghe del falcone • Конфигурации удлинителя стрелы | 8 |
| Working range • Arbeitsbereiche • Diagramme de levage • Gama de trabajo Area di lavoro • Грузовысотные характеристики | 9 |
| Telescopic boom • Teleskopausleger • Flèche principale • Pluma telescópica Braccio telescopico • Телескопическая стрела | 10 |
| Working range • Arbeitsbereiche • Diagramme de levage • Gama de trabajo Area di lavoro • Грузовысотные характеристики | 20 |
| Swingaway (hydraulic luffing) • Klappspitze (hydraulisch wippbar) • Extension treillis (déport hydraulique) Plumín (angulable hidráulicamente) • Falcone (brandeggio idraulico) Складной удлинитель стрелы (гидравлическое изменение вылета) | 21 |
| Specification | 24 |
| Technische Daten | 25 |
| Caractéristiques techniques | 26 |
| Características | 27 |
| Caratteristiche | 28 |
| Технические характеристики | 29 |
| Load charts • Traglasten • Capacités de levage • Capacidades • Capacità • Таблицы грузоподъемности | 30 |
| Symbols • Symbolerklärung • Glossaire des symboles • Glosario de simbolos • Glossario dei simboli • Символы | 31 |

Dimensions • Abmessungen • Encombrement Dimensiones • Dimensioni • Размеры

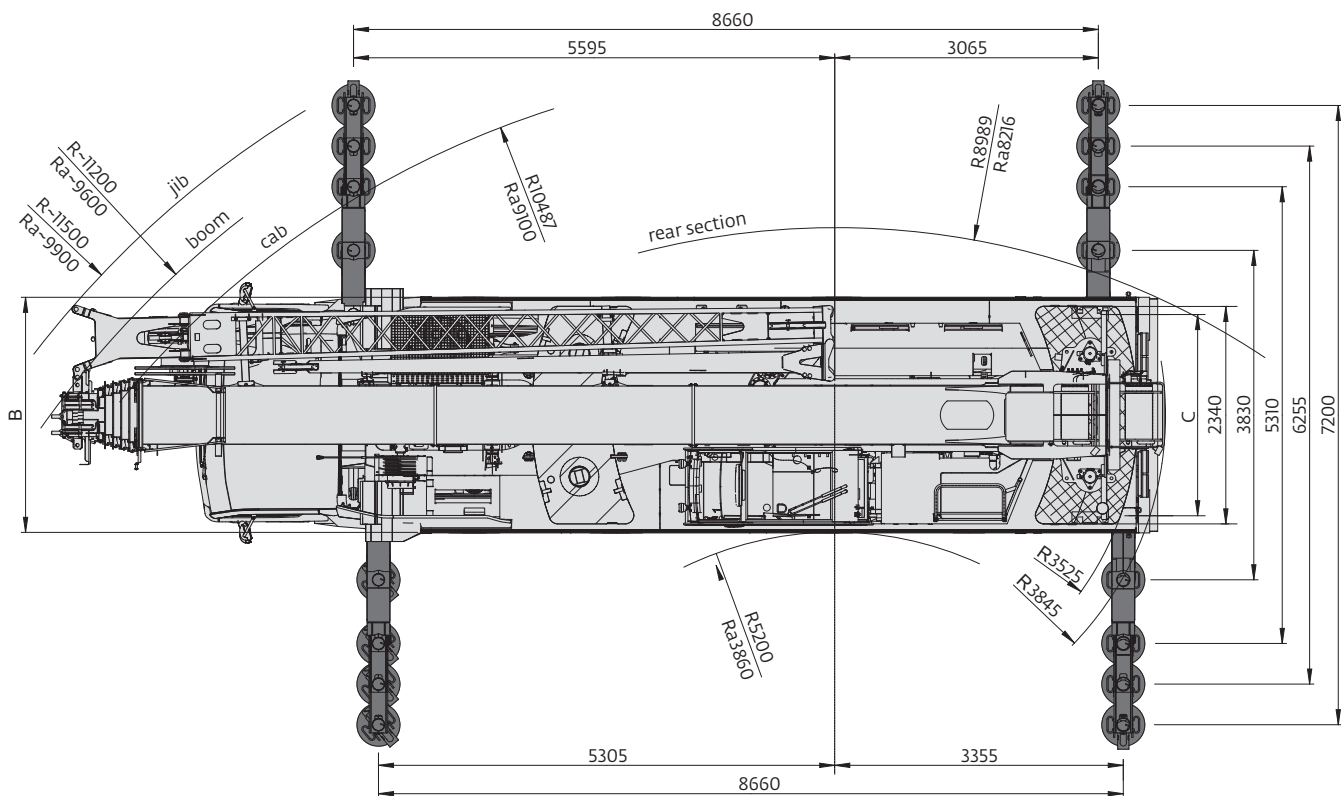
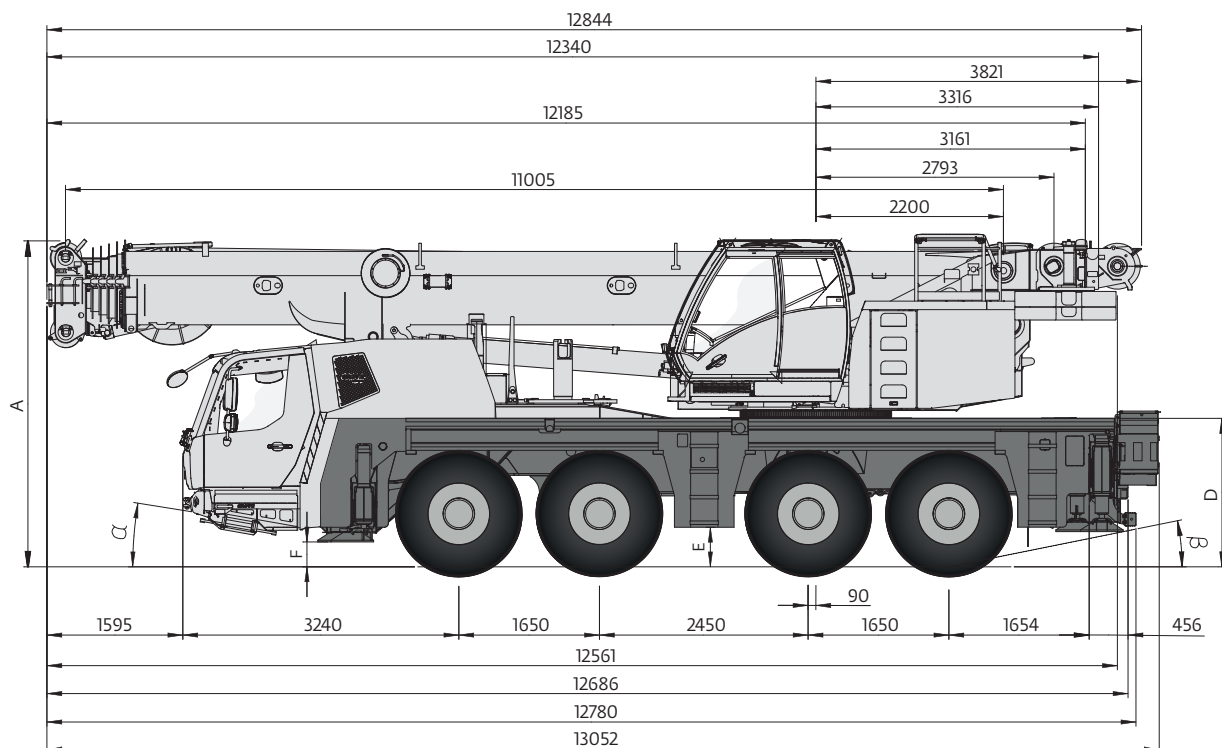



|  | A | A 126 mm* | B | C | D | E | F | α | β | β_1 |
|---|------|--------------|------|------|------|-----|-----|----------|---------|-----------|
| 1400 R25 | 3940 | 3810 | 2550 | 2320 | 1750 | 435 | 262 | 14° | 21° | 17° |
| 1600 R25 | 3990 | 3860 | 2750 | 2280 | 1863 | 485 | 292 | 16° | 23° | 19° |
| 205 R25 | 3990 | 3860 | 2880 | 2320 | 1863 | 485 | 292 | 16° | 23° | 19° |

* lowered • abgesenkt • surbaissée • abbassato • rebaja • сниженный

Dimensions • Abmessungen • Encombremet Dimensiones • Dimensioni • Размеры

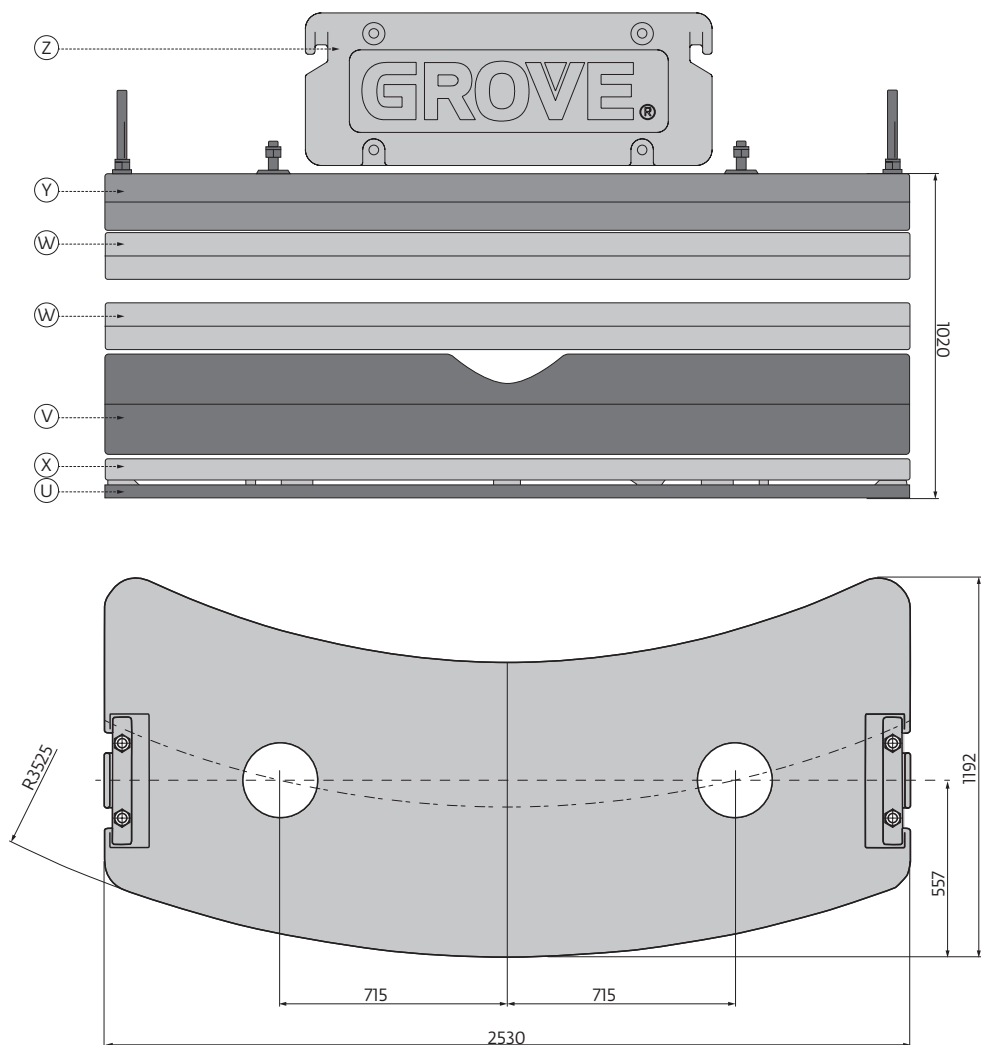
Counterweight • Gegengewicht • Contrepoids • Contrapesos • Contrappesi • Противовес



|  | Z 0,5 t | Y 2,9 t | X 1,15 t | W 2,3 t | V 4,6 t | U 1,1 t |
|---|------------|------------|-------------|------------|------------|------------|
| 0,5 t | x | | | | | |
| 3,4 t | x | x | | | | |
| 4,5 t | x | x | | | | x |
| 5,7 t | x | x | | x | | |
| 5,7 t | x | x | x | | | x |
| 6,8 t | x | x | | x | | x |
| 8,0 t | x | x | | 2x | | |
| 8,0 t | x | x | x | x | | x |
| 9,1 t | x | x | | 2x | | x |
| 10,2 t | x | x | x | 2x | | x |
| 11,4 t | x | x | | x | x | x |
| 12,5 t | x | x | x | x | x | x |
| 13,7 t | x | x | | 2x | x | x |
| 14,8 t | x | x | x | 2x | x | x |

Data • Daten • Caractéristiques • Datos • Dati • Данные

| | Total | | | | | | | | | |
|---------|-------------|-------|-----------------|-------------|------|---|---|----------|---|---|
| < 10000 | on request* | | | | | | | | | x |
| 12000 | 48000 | 8x6x8 | 445/95R25 steel | 1 sheave | 8 | x | x | 8,7/15 m | x | |
| 12000 | 48000 | 8x6x8 | 445/95R25 steel | 3 sheave | 9,1 | x | | | x | |
| 12000 | 48000 | 8x6x8 | 385/95R25 alu | single line | 9,1 | x | | 8,7/15 m | x | |
| 12000 | 48000 | 8x6x8 | 385/95R25 steel | single line | 10,2 | | | | x | |
| 12000 | 48000 | 8x8x8 | 385/95R25 alu | 1 sheave | 10,2 | x | | | x | |
| < 16500 | 58500 | 8x8x8 | 445/95R25 steel | 5 sheave | 14,8 | x | x | 8,7/15 m | x | |

* on request • auf Anfrage • sur demande • su richiesta • bajo demanda • a pedido • no zaprosy

Tolerances may occur. For detailed weight information refer to axle weight calculation sheets. • Toleranzbedingte Abweichungen können auftreten. Detaillierte Gewichtsangaben erhalten Sie durch eine Achslastkalkulation. • Des tolérances sont acceptables. Pour des informations de poids détaillées, se reporter aux planches de calcul de poids de l'essieu. • Se acceptan tolerancias. Para obtener información detallada sobre el peso, consulte las hojas de cálculo de peso de los ejes. • Ci possono essere tolleranze. Per informazioni dettagliate sul peso consultare i fogli di calcolo del peso dell'asse. • Возможны отклонения. Подробную информацию по массе см. в расчетных таблицах нагрузки на ось.



| Lifting capacity Traglast Force de levage Capacidad de elevación Capacità di sollevamento Грузоподъемность | Sheaves Rollen Poulies Poleas Carrucole Шкивы | Weight Gewicht Poids Peso Peso Масса | Parts of line Stränge Brins Ramales de cable Numero di funi Кратность запасовки | Possible load with crane* Mögliche Traglast am Kran* Capacité possible sur la grue* Carga posible con la grue* Portata ammissibile con la gru* Допустимая нагрузка для крана* |
|---|--|---|--|--|
| 80 t | 7 | 800 kg | 2 - 12 / 15** | 58 t / 74 t** |
| 63 t | 5 | 650 kg | 2 - 11 | 54 t |
| 40 t | 3 | 450 kg | 2 - 7 | 35 t |
| 16 t | 1 | 300 kg | 1 - 3 | 15 t |
| 8 t | H/B | 200 kg | 1 | 5 t |

* Varies depending on national regulations. • Variiert je nach Ländervorschrift. • Variaciones dependiendo de las regulaciones nacionales. • Varia in funzione delle normative nazionali. • изменяется в зависимости от национальных норм.

** Requires additional boom nose sheave. • Zusatzausrüstung am Rollenkopf erforderlich. • Demande d'utiliser une poulie auxiliaire de tête de flèche. • Requiere polea adicional en la cabeza de pluma. • E' richiesta una carrucola addizionale sulla testa del braccio. • требует наличия дополнительного шкива в оголовке стрелы.

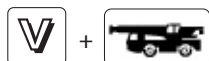

| | 1 | 2 | 3 | 4 | 5 | 6 | 7 | 8 | 9 | 10 | 11 | 12 | 13 | 14 | 15 | 16 | R1 | R2 | |
|------|----------|-----|-----|------|------|------|------|------|------|------|------|------|------|------|------|------|-----|-----|------|
| km/h | 6,4 | 7,6 | 9,4 | 11,3 | 14,1 | 16,9 | 20,0 | 25,0 | 28,0 | 34,0 | 41,0 | 50,0 | 62,0 | 75,0 | 85,0 | 85,0 | 6,4 | 7,8 | |
| km/h | 2,9 | 3,5 | 4,2 | 5,1 | 6,4 | 7,6 | 9,0 | 11,0 | 13,0 | 15,0 | 19,0 | 23,0 | 28,0 | 34,0 | 41,0 | 49,0 | 2,9 | 3,5 | 70 % |
| | 1400 R25 | | | | | | | | | | | | | | | | | | |



| | Infinitely variable Stufenlos verstellbar Progressivement variable Infinitamente variable Infinitamente variabile Плавно-изменяемый | Rope Seil Câble Cable Fune Канат | Max. single line pull Max. Seilzug Effort maxi au brin simple Tiro máximo por ramal Tiro max. per singola fune Макс. натяжение каната |
|--|--|---|--|
| | 0 - 120 m/min Single line • Einfacher Strang Brin simple • Ramal simple • Tiro a fune singola • Однократная запасовка | 16 mm/220 m | 50,0 kN |
| | 0 - 120 m/min Single line • Einfacher Strang Brin simple • Ramal simple • Tiro a fune singola • Однократная запасовка | 16 mm/220 m | 50,0 kN |
| | 0 - 1,7 min ⁻¹ | | |
| | -3,0° to + 82° approx. < 45 s • ca. < 45 s env. < 45 s • aproximadamente < 45 s aproximadamente < 45 s • примерно < 45 с | | |
| | 11,3 to 51,0 m approx. < 335 s • ca. < 335 s env. < 335 s • aproximadamente < 335 s aproximadamente < 335 s • примерно < 335 с | | |

Load charts • Traglasten • Capacités de levage Capacidades • Capacità • Таблицы грузоподъемности

Jib configurations • Kombination der Auslegerverlängerung • Combinaisons de l'extension treillis • Configuración con extensiones de pluma • Combinazioni delle prolunghere del falcone • Конфигурации удлинителя стрелы

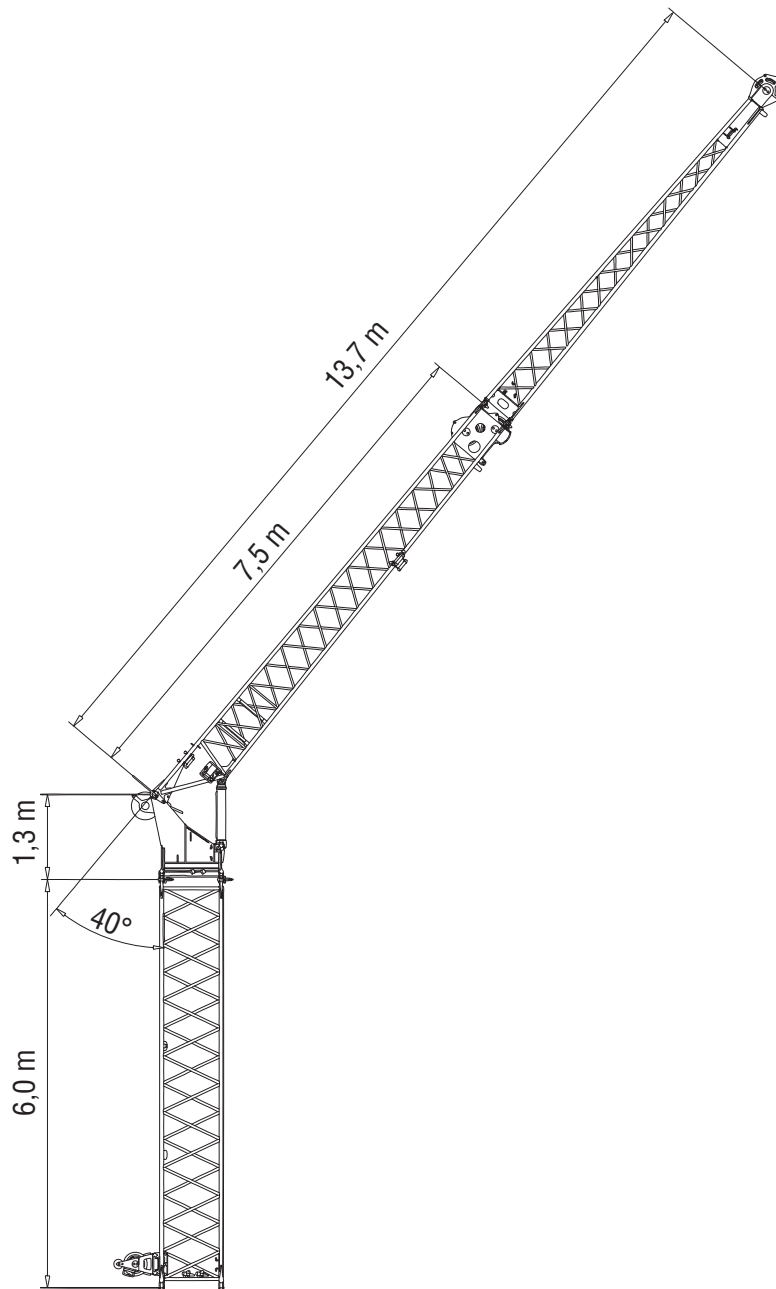

| Total length Gesamtlänge Longueur totale Longitud total Lunghezza Totale Общая длина | Intermediate section boom extension make-up Reihenfolge des Spitzenaufbaus Ordre des combinaisons de l'extension treillis Combinaciones de tramos intermedios de extensión de pluma Sequenza di combinazioni per le sezioni di traliccio del falcone Сборка промежуточной секции гуська крана | | | |
|---|--|-------|-------|-------|
| [m] | 6,0 m | 1,3 m | 7,5 m | 6,2 m |
| 8,7 | - | 1x | 1x | - |
| 15,0 | - | 1x | 1x | 1x |
| 21,0 | 1x | 1x | 1x | 1x |

Working range • Arbeitsbereiche • Diagramme de levage Gama de trabajo • Area di lavoro • Грузовысотные характеристики

Telescopic boom • Teleskopausleger • Flèche principale • Pluma telescópica
Braccio telescopico • Телескопическая стрела



11,0 - 51,0 m



7,2 m



360°

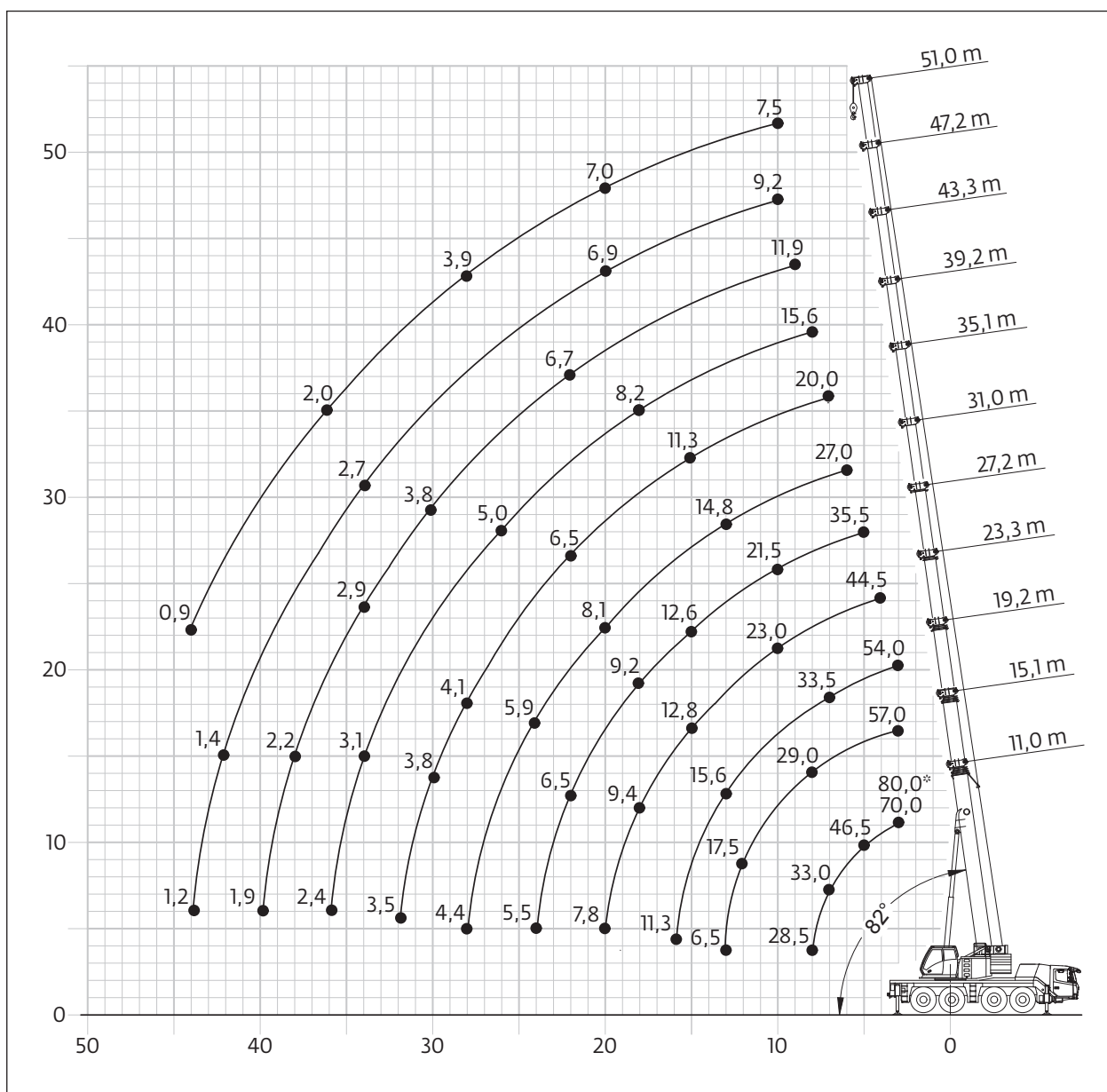

| | Hook block • Hakenflasche • Crochet-moufle • Gancho • Ganci • Крюковой блок | H (mm) |
|-------|---|--------|
| | (t) | |
| | 80 D | 3200 |
| | 63 D | 3000 |
| | 40 D | 2900 |
| 16 E | 2800 | |
| 8 H/B | 2350 | |

Load charts • Traglasten • Capacités de levage Capacidades • Capacità • Таблицы грузоподъемности

Telescopic boom • Teleskopausleger • Flèche principale • Pluma telescópica
Braccio telescopico • Телескопическая стрела



11,0 - 51,0 m



7,2 m



360°



14,8 t



EN 13000

| m | 11,0 | 15,1 | 19,2 | 23,3 | 27,2 | 31,0 | 35,1 | 39,2 | 43,3 | 47,2 | 51,0 | m |
|------|-------|------|------|------|------|------|------|------|------|------|------|------|
| 3,0 | 80,0* | | | | | | | | | | | 3,0 |
| 3,0 | 70,0 | | | | | | | | | | | 3,0 |
| 4,0 | 53,5 | 50,5 | 47,0 | 44,5 | | | | | | | | 4,0 |
| 5,0 | 46,5 | 45,0 | 42,0 | 39,0 | 35,5 | | | | | | | 5,0 |
| 6,0 | 39,5 | 39,5 | 38,0 | 35,5 | 33,5 | 27,0 | | | | | | 6,0 |
| 7,0 | 33,0 | 33,5 | 33,5 | 32,0 | 31,0 | 26,0 | 20,0 | | | | | 7,0 |
| 8,0 | 28,5 | 29,0 | 29,0 | 28,5 | 28,5 | 25,0 | 19,7 | 15,6 | | | | 8,0 |
| 9,0 | | 25,5 | 25,5 | 25,0 | 25,0 | 23,5 | 18,6 | 15,4 | 11,9 | | | 9,0 |
| 10,0 | | 23,0 | 22,5 | 23,0 | 21,5 | 21,5 | 17,5 | 15,2 | 11,9 | 9,2 | 7,5 | 10,0 |
| 11,0 | | 20,5 | 20,5 | 20,0 | 19,2 | 18,6 | 16,4 | 14,4 | 11,9 | 9,2 | 7,5 | 11,0 |
| 12,0 | | 17,5 | 17,9 | 17,8 | 17,8 | 16,5 | 15,3 | 13,7 | 11,9 | 9,2 | 7,5 | 12,0 |
| 13,0 | | 6,5 | 15,6 | 15,5 | 15,9 | 14,8 | 13,8 | 12,9 | 11,5 | 9,2 | 7,5 | 13,0 |
| 14,0 | | | 13,7 | 14,1 | 14,2 | 13,3 | 12,4 | 12,0 | 11,1 | 9,2 | 7,5 | 14,0 |
| 15,0 | | | 12,3 | 12,8 | 12,6 | 12,0 | 11,3 | 10,8 | 10,5 | 9,2 | 7,5 | 15,0 |
| 16,0 | | | 11,3 | 11,5 | 11,3 | 10,9 | 10,8 | 9,8 | 9,7 | 9,0 | 7,5 | 16,0 |
| 18,0 | | | | 9,4 | 9,2 | 9,1 | 9,3 | 8,2 | 8,1 | 8,2 | 7,5 | 18,0 |
| 20,0 | | | | 7,8 | 7,7 | 8,1 | 7,7 | 7,4 | 6,9 | 6,9 | 7,0 | 20,0 |
| 22,0 | | | | | 6,5 | 6,9 | 6,5 | 6,7 | 6,4 | 6,3 | 6,1 | 22,0 |
| 24,0 | | | | | 5,5 | 5,9 | 5,5 | 5,7 | 5,7 | 5,7 | 5,2 | 24,0 |
| 26,0 | | | | | | 5,1 | 4,7 | 5,0 | 4,9 | 4,8 | 4,5 | 26,0 |
| 28,0 | | | | | | 4,4 | 4,1 | 4,5 | 4,4 | 4,2 | 3,9 | 28,0 |
| 30,0 | | | | | | | 3,8 | 4,0 | 3,8 | 3,6 | 3,3 | 30,0 |
| 32,0 | | | | | | | 3,5 | 3,5 | 3,3 | 3,1 | 2,8 | 32,0 |
| 34,0 | | | | | | | | 3,1 | 2,9 | 2,7 | 2,4 | 34,0 |
| 36,0 | | | | | | | | 2,4 | 2,5 | 2,3 | 2,0 | 36,0 |
| 38,0 | | | | | | | | | 2,2 | 2,0 | 1,7 | 38,0 |
| 40,0 | | | | | | | | | 1,9 | 1,7 | 1,4 | 40,0 |
| 42,0 | | | | | | | | | | 1,4 | 1,1 | 42,0 |
| 44,0 | | | | | | | | | | 1,2 | 0,9 | 44,0 |

* Over rear with special equipment. • Nach hinten mit Sonderausüstung. • En arrière avec équipement supplémentaire. • Por la parte trasera con equipo adicional.
Sul posteriore con equipaggiamento ausiliario. • Над задней частью со специальным оборудованием.

Load charts • Traglasten • Capacités de levage Capacidades • Capacità • Таблицы грузоподъемности

Telescopic boom • Teleskopausleger • Flèche principale • Pluma telescópica
Braccio telescopico • Телескопическая стрела



11,0 - 51,0 m



7,2 m



360°



13,7t



EN 13000

| m | 11,0 | 15,1 | 19,2 | 23,3 | 27,2 | 31,0 | 35,1 | 39,2 | 43,3 | 47,2 | 51,0 | m |
|------|------|------|------|------|------|------|------|------|------|------|------|------|
| 3,0 | 70,0 | 57,0 | 54,0 | | | | | | | | | 3,0 |
| 4,0 | 53,5 | 50,5 | 47,0 | 44,5 | | | | | | | | 4,0 |
| 5,0 | 46,5 | 45,0 | 42,0 | 39,0 | 35,5 | | | | | | | 5,0 |
| 6,0 | 39,0 | 39,0 | 38,0 | 35,5 | 33,5 | 27,0 | | | | | | 6,0 |
| 7,0 | 33,0 | 33,0 | 33,0 | 32,0 | 31,0 | 26,0 | 20,0 | | | | | 7,0 |
| 8,0 | 28,5 | 28,5 | 28,5 | 28,5 | 28,0 | 25,0 | 19,7 | 15,6 | | | | 8,0 |
| 9,0 | | 25,0 | 25,0 | 25,0 | 24,0 | 23,5 | 18,6 | 15,4 | 11,9 | | | 9,0 |
| 10,0 | | 22,5 | 22,0 | 22,0 | 20,5 | 20,5 | 17,5 | 15,2 | 11,9 | 9,2 | 7,5 | 10,0 |
| 11,0 | | 19,6 | 20,0 | 19,3 | 19,2 | 17,9 | 16,4 | 14,4 | 11,9 | 9,2 | 7,5 | 11,0 |
| 12,0 | | 16,7 | 17,2 | 17,0 | 17,0 | 15,8 | 14,8 | 13,7 | 11,9 | 9,2 | 7,5 | 12,0 |
| 13,0 | | 6,5 | 14,9 | 15,1 | 15,2 | 14,1 | 13,2 | 12,7 | 11,5 | 9,2 | 7,5 | 13,0 |
| 14,0 | | | 13,1 | 13,8 | 13,6 | 12,7 | 11,8 | 11,4 | 11,1 | 9,2 | 7,5 | 14,0 |
| 15,0 | | | 12,1 | 12,3 | 12,1 | 11,5 | 11,3 | 10,3 | 10,2 | 9,2 | 7,5 | 15,0 |
| 16,0 | | | 10,9 | 11,0 | 10,8 | 10,4 | 10,7 | 9,3 | 9,2 | 9,0 | 7,5 | 16,0 |
| 18,0 | | | | 9,0 | 8,8 | 9,1 | 8,9 | 8,0 | 7,7 | 7,8 | 7,5 | 18,0 |
| 20,0 | | | | 7,5 | 7,3 | 7,7 | 7,3 | 7,4 | 6,9 | 6,9 | 6,7 | 20,0 |
| 22,0 | | | | | 6,1 | 6,5 | 6,2 | 6,4 | 6,4 | 6,2 | 5,7 | 22,0 |
| 24,0 | | | | | 5,2 | 5,6 | 5,2 | 5,4 | 5,4 | 5,4 | 4,9 | 24,0 |
| 26,0 | | | | | | 4,8 | 4,4 | 5,0 | 4,8 | 4,6 | 4,2 | 26,0 |
| 28,0 | | | | | | 4,1 | 4,1 | 4,3 | 4,1 | 3,9 | 3,6 | 28,0 |
| 30,0 | | | | | | | 3,8 | 3,7 | 3,6 | 3,4 | 3,1 | 30,0 |
| 32,0 | | | | | | | 3,4 | 3,3 | 3,1 | 2,9 | 2,6 | 32,0 |
| 34,0 | | | | | | | | 2,9 | 2,7 | 2,5 | 2,2 | 34,0 |
| 36,0 | | | | | | | | 2,5 | 2,3 | 2,1 | 1,8 | 36,0 |
| 38,0 | | | | | | | | | 2,0 | 1,8 | 1,5 | 38,0 |
| 40,0 | | | | | | | | | 1,7 | 1,5 | 1,2 | 40,0 |
| 42,0 | | | | | | | | | | 1,2 | 1,0 | 42,0 |
| 44,0 | | | | | | | | | | 1,0 | | 44,0 |

Load charts • Traglasten • Capacités de levage Capacidades • Capacità • Таблицы грузоподъемности

Telescopic boom • Teleskopausleger • Flèche principale • Pluma telescópica
Braccio telescopico • Телескопическая стрела



11,0 - 51,0 m



7,2 m



360°



12,5 t



EN 13000

| m | 11,0 | 15,1 | 19,2 | 23,3 | 27,2 | 31,0 | 35,1 | 39,2 | 43,3 | 47,2 | 51,0 | m |
|------|------|------|------|------|------|------|------|------|------|------|------|------|
| 3,0 | 70,0 | 57,0 | 54,0 | | | | | | | | | 3,0 |
| 4,0 | 53,5 | 50,5 | 47,0 | 44,5 | | | | | | | | 4,0 |
| 5,0 | 46,5 | 45,0 | 42,0 | 39,0 | 35,5 | | | | | | | 5,0 |
| 6,0 | 38,5 | 39,0 | 38,0 | 35,5 | 33,5 | 27,0 | | | | | | 6,0 |
| 7,0 | 32,5 | 33,0 | 33,0 | 32,0 | 31,0 | 26,0 | 20,0 | | | | | 7,0 |
| 8,0 | 28,0 | 28,5 | 28,5 | 28,0 | 27,0 | 25,0 | 19,7 | 15,6 | | | | 8,0 |
| 9,0 | | 25,0 | 25,0 | 25,0 | 23,0 | 22,5 | 18,6 | 15,4 | 11,9 | | | 9,0 |
| 10,0 | | 22,0 | 22,0 | 21,0 | 20,5 | 19,5 | 17,5 | 15,2 | 11,9 | 9,2 | 7,5 | 10,0 |
| 11,0 | | 18,8 | 19,2 | 18,5 | 18,4 | 17,1 | 16,0 | 14,4 | 11,9 | 9,2 | 7,5 | 11,0 |
| 12,0 | | 16,0 | 16,5 | 16,3 | 16,3 | 15,1 | 14,1 | 13,6 | 11,9 | 9,2 | 7,5 | 12,0 |
| 13,0 | | 6,5 | 14,3 | 15,0 | 14,6 | 13,5 | 12,6 | 12,1 | 11,5 | 9,2 | 7,5 | 13,0 |
| 14,0 | | | 13,0 | 13,2 | 13,0 | 12,1 | 11,8 | 10,8 | 10,7 | 9,2 | 7,5 | 14,0 |
| 15,0 | | | 11,6 | 11,7 | 11,6 | 10,9 | 11,1 | 9,8 | 9,7 | 9,2 | 7,5 | 15,0 |
| 16,0 | | | 10,4 | 10,5 | 10,3 | 9,9 | 10,2 | 8,8 | 8,8 | 8,8 | 7,5 | 16,0 |
| 18,0 | | | | 8,6 | 8,4 | 8,8 | 8,4 | 8,0 | 7,5 | 7,5 | 7,5 | 18,0 |
| 20,0 | | | | 7,1 | 6,9 | 7,4 | 7,0 | 7,2 | 6,9 | 6,8 | 6,3 | 20,0 |
| 22,0 | | | | | 5,8 | 6,2 | 5,8 | 6,0 | 6,1 | 5,9 | 5,4 | 22,0 |
| 24,0 | | | | | 4,9 | 5,3 | 4,9 | 5,4 | 5,3 | 5,1 | 4,6 | 24,0 |
| 26,0 | | | | | | 4,5 | 4,4 | 4,7 | 4,5 | 4,3 | 3,9 | 26,0 |
| 28,0 | | | | | | 4,0 | 4,1 | 4,1 | 3,9 | 3,7 | 3,4 | 28,0 |
| 30,0 | | | | | | | 3,6 | 3,5 | 3,3 | 3,1 | 2,8 | 30,0 |
| 32,0 | | | | | | | 3,2 | 3,1 | 2,9 | 2,7 | 2,4 | 32,0 |
| 34,0 | | | | | | | | 2,7 | 2,5 | 2,3 | 2,0 | 34,0 |
| 36,0 | | | | | | | | 2,3 | 2,1 | 1,9 | 1,6 | 36,0 |
| 38,0 | | | | | | | | | 1,8 | 1,6 | 1,3 | 38,0 |
| 40,0 | | | | | | | | | 1,5 | 1,3 | 1,1 | 40,0 |
| 42,0 | | | | | | | | | | 1,1 | 0,8 | 42,0 |
| 44,0 | | | | | | | | | | 0,9 | | 44,0 |

Load charts • Traglasten • Capacités de levage Capacidades • Capacità • Таблицы грузоподъемности

Telescopic boom • Teleskopausleger • Flèche principale • Pluma telescópica
Braccio telescopico • Телескопическая стрела



11,0 - 51,0 m



7,2 m



360°



11,4 t



EN 13000

| m | 11,0 | 15,1 | 19,2 | 23,3 | 27,2 | 31,0 | 35,1 | 39,2 | 43,3 | 47,2 | 51,0 | m |
|------|------|------|------|------|------|------|------|------|------|------|------|------|
| 3,0 | 70,0 | 57,0 | 54,0 | | | | | | | | | 3,0 |
| 4,0 | 53,5 | 50,5 | 47,0 | 44,5 | | | | | | | | 4,0 |
| 5,0 | 46,0 | 45,0 | 42,0 | 39,0 | 35,5 | | | | | | | 5,0 |
| 6,0 | 38,0 | 38,5 | 38,0 | 35,5 | 33,5 | 27,0 | | | | | | 6,0 |
| 7,0 | 32,0 | 32,5 | 32,5 | 32,0 | 31,0 | 26,0 | 20,0 | | | | | 7,0 |
| 8,0 | 27,5 | 28,0 | 28,0 | 27,0 | 26,0 | 25,0 | 19,7 | 15,6 | | | | 8,0 |
| 9,0 | | 25,0 | 24,0 | 23,5 | 22,5 | 21,5 | 18,6 | 15,4 | 11,9 | | | 9,0 |
| 10,0 | | 21,5 | 21,5 | 20,5 | 20,0 | 18,7 | 17,4 | 15,2 | 11,9 | 9,2 | 7,5 | 10,0 |
| 11,0 | | 17,9 | 18,4 | 17,7 | 17,6 | 16,3 | 15,2 | 14,4 | 11,9 | 9,2 | 7,5 | 11,0 |
| 12,0 | | 15,3 | 15,7 | 16,1 | 15,6 | 14,4 | 13,5 | 12,9 | 11,9 | 9,2 | 7,5 | 12,0 |
| 13,0 | | 6,5 | 13,8 | 14,4 | 13,9 | 12,9 | 12,3 | 11,5 | 11,3 | 9,2 | 7,5 | 13,0 |
| 14,0 | | | 12,5 | 12,6 | 12,4 | 11,5 | 11,7 | 10,3 | 10,2 | 9,2 | 7,5 | 14,0 |
| 15,0 | | | 11,1 | 11,2 | 11,0 | 10,4 | 10,6 | 9,2 | 9,2 | 9,2 | 7,5 | 15,0 |
| 16,0 | | | 9,9 | 10,0 | 9,8 | 9,9 | 9,6 | 8,7 | 8,3 | 8,3 | 7,5 | 16,0 |
| 18,0 | | | | 8,1 | 8,0 | 8,4 | 8,0 | 8,0 | 7,5 | 7,5 | 7,0 | 18,0 |
| 20,0 | | | | 6,7 | 6,6 | 7,0 | 6,6 | 6,8 | 6,7 | 6,5 | 5,9 | 20,0 |
| 22,0 | | | | | 5,5 | 5,9 | 5,5 | 5,9 | 5,9 | 5,5 | 5,0 | 22,0 |
| 24,0 | | | | | 4,6 | 5,0 | 4,8 | 5,2 | 5,0 | 4,7 | 4,3 | 24,0 |
| 26,0 | | | | | | 4,3 | 4,4 | 4,4 | 4,2 | 4,0 | 3,7 | 26,0 |
| 28,0 | | | | | | 4,0 | 3,9 | 3,8 | 3,6 | 3,4 | 3,1 | 28,0 |
| 30,0 | | | | | | | 3,4 | 3,3 | 3,1 | 2,9 | 2,6 | 30,0 |
| 32,0 | | | | | | | 2,9 | 2,8 | 2,7 | 2,5 | 2,2 | 32,0 |
| 34,0 | | | | | | | | 2,5 | 2,3 | 2,1 | 1,8 | 34,0 |
| 36,0 | | | | | | | | 2,1 | 1,9 | 1,7 | 1,4 | 36,0 |
| 38,0 | | | | | | | | | 1,6 | 1,4 | 1,1 | 38,0 |
| 40,0 | | | | | | | | | 1,4 | 1,2 | 0,9 | 40,0 |
| 42,0 | | | | | | | | | | 0,9 | | 42,0 |

Load charts • Traglasten • Capacités de levage Capacidades • Capacità • Таблицы грузоподъемности

Telescopic boom • Teleskopausleger • Flèche principale • Pluma telescópica
Braccio telescopico • Телескопическая стрела



11,0 - 51,0 m



7,2 m



360°



10,2 t



EN 13000

| m | 11,0 | 15,1 | 19,2 | 23,3 | 27,2 | 31,0 | 35,1 | 39,2 | 43,3 | 47,2 | 51,0 | m |
|------|------|------|------|------|------|------|------|------|------|------|------|------|
| 3,0 | 70,0 | 57,0 | 54,0 | | | | | | | | | 3,0 |
| 4,0 | 53,5 | 50,5 | 47,0 | 44,5 | | | | | | | | 4,0 |
| 5,0 | 45,5 | 45,0 | 42,0 | 39,0 | 35,5 | | | | | | | 5,0 |
| 6,0 | 37,5 | 38,0 | 38,0 | 35,5 | 33,5 | 27,0 | | | | | | 6,0 |
| 7,0 | 32,0 | 32,0 | 32,0 | 31,5 | 30,0 | 26,0 | 20,0 | | | | | 7,0 |
| 8,0 | 27,5 | 27,5 | 27,5 | 27,0 | 25,0 | 24,5 | 19,7 | 15,6 | | | | 8,0 |
| 9,0 | | 24,5 | 24,0 | 22,5 | 22,5 | 20,5 | 18,6 | 15,4 | 11,9 | | | 9,0 |
| 10,0 | | 20,5 | 20,5 | 19,4 | 19,3 | 17,8 | 16,6 | 15,2 | 11,9 | 9,2 | 7,5 | 10,0 |
| 11,0 | | 17,1 | 17,6 | 17,3 | 16,9 | 15,6 | 14,5 | 13,9 | 11,9 | 9,2 | 7,5 | 11,0 |
| 12,0 | | 14,6 | 15,0 | 15,8 | 14,9 | 13,7 | 12,9 | 12,3 | 11,9 | 9,2 | 7,5 | 12,0 |
| 13,0 | | 6,5 | 13,5 | 13,7 | 13,3 | 12,2 | 12,3 | 10,9 | 10,7 | 9,2 | 7,5 | 13,0 |
| 14,0 | | | 11,9 | 12,0 | 11,9 | 10,9 | 11,1 | 9,7 | 9,6 | 9,2 | 7,5 | 14,0 |
| 15,0 | | | 10,5 | 10,7 | 10,5 | 10,4 | 10,1 | 9,1 | 8,6 | 8,7 | 7,5 | 15,0 |
| 16,0 | | | 9,4 | 9,5 | 9,4 | 9,8 | 9,1 | 8,7 | 8,2 | 8,2 | 7,5 | 16,0 |
| 18,0 | | | | 7,7 | 7,6 | 8,0 | 7,6 | 7,6 | 7,5 | 7,2 | 6,6 | 18,0 |
| 20,0 | | | | 6,5 | 6,2 | 6,6 | 6,2 | 6,4 | 6,5 | 6,1 | 5,6 | 20,0 |
| 22,0 | | | | | 5,1 | 5,5 | 5,3 | 5,7 | 5,6 | 5,2 | 4,7 | 22,0 |
| 24,0 | | | | | 4,3 | 4,7 | 4,8 | 4,9 | 4,7 | 4,4 | 4,0 | 24,0 |
| 26,0 | | | | | | 4,3 | 4,2 | 4,1 | 4,0 | 3,8 | 3,4 | 26,0 |
| 28,0 | | | | | | 3,8 | 3,6 | 3,6 | 3,4 | 3,2 | 2,8 | 28,0 |
| 30,0 | | | | | | | 3,1 | 3,1 | 2,9 | 2,7 | 2,4 | 30,0 |
| 32,0 | | | | | | | 2,7 | 2,6 | 2,4 | 2,2 | 2,0 | 32,0 |
| 34,0 | | | | | | | | 2,3 | 2,1 | 1,9 | 1,6 | 34,0 |
| 36,0 | | | | | | | | 1,9 | 1,7 | 1,5 | 1,3 | 36,0 |
| 38,0 | | | | | | | | | 1,5 | 1,3 | 1,0 | 38,0 |
| 40,0 | | | | | | | | | 1,2 | 1,0 | | 40,0 |

Load charts • Traglasten • Capacités de levage Capacidades • Capacità • Таблицы грузоподъемности

Telescopic boom • Teleskopausleger • Flèche principale • Pluma telescópica
Braccio telescopico • Телескопическая стрела



11,0 - 51,0 m



7,2 m



360 °



9,1 t



EN 13000

| m | 11,0 | 15,1 | 19,2 | 23,3 | 27,2 | 31,0 | 35,1 | 39,2 | 43,3 | 47,2 | 51,0 | m |
|------|------|------|------|------|------|------|------|------|------|------|------|------|
| 3,0 | 70,0 | 57,0 | 54,0 | | | | | | | | | 3,0 |
| 4,0 | 53,5 | 50,5 | 47,0 | 44,5 | | | | | | | | 4,0 |
| 5,0 | 45,0 | 45,0 | 42,0 | 39,0 | 35,5 | | | | | | | 5,0 |
| 6,0 | 37,0 | 37,5 | 37,5 | 35,5 | 33,5 | 27,0 | | | | | | 6,0 |
| 7,0 | 31,5 | 32,0 | 32,0 | 30,0 | 29,0 | 26,0 | 20,0 | | | | | 7,0 |
| 8,0 | 27,0 | 27,5 | 26,5 | 26,0 | 24,0 | 23,0 | 19,7 | 15,6 | | | | 8,0 |
| 9,0 | | 23,5 | 23,0 | 21,5 | 21,5 | 19,7 | 18,3 | 15,4 | 11,9 | | | 9,0 |
| 10,0 | | 19,4 | 19,7 | 18,6 | 18,4 | 17,0 | 15,8 | 15,1 | 11,9 | 9,2 | 7,5 | 10,0 |
| 11,0 | | 16,3 | 16,8 | 17,0 | 16,1 | 14,8 | 13,8 | 13,2 | 11,9 | 9,2 | 7,5 | 11,0 |
| 12,0 | | 13,8 | 14,7 | 15,0 | 14,2 | 13,0 | 12,9 | 11,6 | 11,4 | 9,2 | 7,5 | 12,0 |
| 13,0 | | 6,5 | 12,9 | 13,1 | 12,6 | 11,6 | 11,8 | 10,3 | 10,1 | 9,2 | 7,5 | 13,0 |
| 14,0 | | | 11,3 | 11,5 | 11,3 | 10,9 | 10,6 | 9,6 | 9,1 | 9,1 | 7,5 | 14,0 |
| 15,0 | | | 10,0 | 10,1 | 10,0 | 10,4 | 9,5 | 9,1 | 8,6 | 8,5 | 7,5 | 15,0 |
| 16,0 | | | 8,9 | 9,0 | 8,9 | 9,3 | 8,6 | 8,6 | 8,2 | 8,1 | 7,5 | 16,0 |
| 18,0 | | | | 7,3 | 7,1 | 7,6 | 7,2 | 7,2 | 7,2 | 6,8 | 6,2 | 18,0 |
| 20,0 | | | | 6,4 | 5,8 | 6,3 | 5,9 | 6,4 | 6,1 | 5,7 | 5,2 | 20,0 |
| 22,0 | | | | | 4,8 | 5,2 | 5,3 | 5,4 | 5,2 | 4,8 | 4,4 | 22,0 |
| 24,0 | | | | | 4,0 | 4,5 | 4,7 | 4,6 | 4,4 | 4,1 | 3,7 | 24,0 |
| 26,0 | | | | | | 4,1 | 4,0 | 3,9 | 3,7 | 3,5 | 3,1 | 26,0 |
| 28,0 | | | | | | 3,5 | 3,4 | 3,3 | 3,1 | 2,9 | 2,6 | 28,0 |
| 30,0 | | | | | | | 2,9 | 2,8 | 2,6 | 2,4 | 2,1 | 30,0 |
| 32,0 | | | | | | | 2,5 | 2,4 | 2,2 | 2,0 | 1,7 | 32,0 |
| 34,0 | | | | | | | | 2,1 | 1,9 | 1,7 | 1,4 | 34,0 |
| 36,0 | | | | | | | | 1,8 | 1,6 | 1,4 | 1,1 | 36,0 |
| 38,0 | | | | | | | | | 1,3 | 1,1 | 0,8 | 38,0 |
| 40,0 | | | | | | | | | 1,0 | 0,8 | | 40,0 |

Load charts • Traglasten • Capacités de levage Capacidades • Capacità • Таблицы грузоподъемности

Telescopic boom • Teleskopausleger • Flèche principale • Pluma telescópica
Braccio telescopico • Телескопическая стрела



11,0 - 51,0 m



7,2 m



360°



8,0 t



EN 13000

| m | 11,0 | 15,1 | 19,2 | 23,3 | 27,2 | 31,0 | 35,1 | 39,2 | 43,3 | 47,2 | 51,0 | m |
|------|------|------|------|------|------|------|------|------|------|------|------|------|
| 3,0 | 70,0 | 57,0 | 54,0 | | | | | | | | | 3,0 |
| 4,0 | 53,5 | 50,5 | 47,0 | 44,5 | | | | | | | | 4,0 |
| 5,0 | 44,5 | 45,0 | 42,0 | 39,0 | 35,5 | | | | | | | 5,0 |
| 6,0 | 37,0 | 37,0 | 37,0 | 35,5 | 33,5 | 27,0 | | | | | | 6,0 |
| 7,0 | 31,0 | 31,5 | 31,0 | 29,0 | 27,5 | 26,0 | 20,0 | | | | | 7,0 |
| 8,0 | 26,0 | 27,0 | 25,0 | 24,5 | 24,0 | 22,0 | 19,7 | 15,6 | | | | 8,0 |
| 9,0 | | 22,5 | 22,0 | 20,5 | 20,5 | 18,8 | 17,4 | 15,4 | 11,9 | | | 9,0 |
| 10,0 | | 18,4 | 18,7 | 18,6 | 17,5 | 16,2 | 15,0 | 14,3 | 11,9 | 9,2 | 7,5 | 10,0 |
| 11,0 | | 15,5 | 16,0 | 16,2 | 15,3 | 14,1 | 13,7 | 12,5 | 11,9 | 9,2 | 7,5 | 11,0 |
| 12,0 | | 13,3 | 14,2 | 14,3 | 13,5 | 12,4 | 12,5 | 11,0 | 10,8 | 9,2 | 7,5 | 12,0 |
| 13,0 | | 6,5 | 12,3 | 12,4 | 12,0 | 11,5 | 11,2 | 10,1 | 9,6 | 9,2 | 7,5 | 13,0 |
| 14,0 | | | 10,7 | 10,9 | 10,7 | 10,9 | 10,0 | 9,6 | 9,0 | 8,8 | 7,5 | 14,0 |
| 15,0 | | | 9,5 | 9,6 | 9,4 | 9,8 | 9,0 | 9,0 | 8,6 | 8,4 | 7,5 | 15,0 |
| 16,0 | | | 8,4 | 8,6 | 8,4 | 8,9 | 8,2 | 8,1 | 8,0 | 7,6 | 7,0 | 16,0 |
| 18,0 | | | | 7,1 | 6,7 | 7,2 | 6,8 | 7,0 | 6,8 | 6,3 | 5,8 | 18,0 |
| 20,0 | | | | 6,0 | 5,5 | 5,9 | 5,9 | 6,1 | 5,7 | 5,3 | 4,8 | 20,0 |
| 22,0 | | | | | 4,5 | 5,0 | 5,2 | 5,1 | 4,9 | 4,5 | 4,0 | 22,0 |
| 24,0 | | | | | 4,0 | 4,5 | 4,4 | 4,3 | 4,1 | 3,8 | 3,4 | 24,0 |
| 26,0 | | | | | | 3,8 | 3,7 | 3,6 | 3,4 | 3,2 | 2,8 | 26,0 |
| 28,0 | | | | | | 3,3 | 3,2 | 3,1 | 2,9 | 2,7 | 2,3 | 28,0 |
| 30,0 | | | | | | | 2,7 | 2,6 | 2,4 | 2,2 | 1,9 | 30,0 |
| 32,0 | | | | | | | 2,3 | 2,2 | 2,0 | 1,8 | 1,5 | 32,0 |
| 34,0 | | | | | | | | 1,9 | 1,7 | 1,5 | 1,2 | 34,0 |
| 36,0 | | | | | | | | 1,2 | 1,4 | 1,2 | 0,9 | 36,0 |
| 38,0 | | | | | | | | | 1,1 | 0,9 | | 38,0 |
| 40,0 | | | | | | | | | 0,9 | | | 40,0 |

Load charts • Traglasten • Capacités de levage Capacidades • Capacità • Таблицы грузоподъемности

Telescopic boom • Teleskopausleger • Flèche principale • Pluma telescópica
Braccio telescopico • Телескопическая стрела



11,0 - 51,0 m



7,2 m



360°



6,8 t



EN 13000

| m | 11,0 | 15,1 | 19,2 | 23,3 | 27,2 | 31,0 | 35,1 | 39,2 | 43,3 | 47,2 | 51,0 | m |
|------|------|------|------|------|------|------|------|------|------|------|------|------|
| 3,0 | 70,0 | 57,0 | 54,0 | | | | | | | | | 3,0 |
| 4,0 | 53,5 | 50,5 | 47,0 | 44,5 | | | | | | | | 4,0 |
| 5,0 | 44,0 | 44,5 | 42,0 | 39,0 | 35,5 | | | | | | | 5,0 |
| 6,0 | 36,5 | 37,0 | 37,0 | 34,5 | 33,0 | 27,0 | | | | | | 6,0 |
| 7,0 | 31,0 | 31,0 | 29,5 | 28,5 | 26,0 | 25,5 | 20,0 | | | | | 7,0 |
| 8,0 | 25,0 | 25,5 | 25,0 | 23,5 | 23,0 | 21,0 | 19,5 | 15,6 | | | | 8,0 |
| 9,0 | | 21,0 | 21,0 | 20,5 | 19,4 | 17,8 | 16,5 | 15,4 | 11,9 | | | 9,0 |
| 10,0 | | 17,5 | 17,8 | 17,7 | 16,6 | 15,3 | 14,2 | 13,5 | 11,9 | 9,2 | 7,5 | 10,0 |
| 11,0 | | 14,7 | 15,7 | 15,4 | 14,5 | 13,3 | 13,4 | 11,7 | 11,5 | 9,2 | 7,5 | 11,0 |
| 12,0 | | 12,7 | 13,4 | 13,6 | 12,7 | 12,1 | 11,8 | 10,7 | 10,1 | 9,2 | 7,5 | 12,0 |
| 13,0 | | 6,5 | 11,6 | 11,8 | 11,3 | 11,4 | 10,5 | 10,1 | 9,4 | 9,0 | 7,5 | 13,0 |
| 14,0 | | | 10,1 | 10,3 | 10,1 | 10,3 | 9,4 | 9,4 | 9,0 | 8,7 | 7,5 | 14,0 |
| 15,0 | | | 8,9 | 9,1 | 8,9 | 9,3 | 8,5 | 8,4 | 8,4 | 7,9 | 7,3 | 15,0 |
| 16,0 | | | 7,9 | 8,1 | 7,9 | 8,4 | 7,7 | 7,8 | 7,6 | 7,2 | 6,6 | 16,0 |
| 18,0 | | | | 6,9 | 6,3 | 6,7 | 6,5 | 6,8 | 6,4 | 5,9 | 5,4 | 18,0 |
| 20,0 | | | | 5,7 | 5,1 | 5,5 | 5,8 | 5,7 | 5,4 | 5,0 | 4,5 | 20,0 |
| 22,0 | | | | | 4,3 | 4,9 | 4,8 | 4,7 | 4,5 | 4,2 | 3,7 | 22,0 |
| 24,0 | | | | | 4,0 | 4,2 | 4,1 | 4,0 | 3,8 | 3,5 | 3,1 | 24,0 |
| 26,0 | | | | | | 3,5 | 3,4 | 3,3 | 3,2 | 2,9 | 2,5 | 26,0 |
| 28,0 | | | | | | 3,0 | 2,9 | 2,8 | 2,6 | 2,4 | 2,0 | 28,0 |
| 30,0 | | | | | | | 2,5 | 2,4 | 2,2 | 2,0 | 1,6 | 30,0 |
| 32,0 | | | | | | | 2,1 | 2,0 | 1,8 | 1,6 | 1,3 | 32,0 |
| 34,0 | | | | | | | | 1,7 | 1,5 | 1,3 | 1,0 | 34,0 |
| 36,0 | | | | | | | | 1,4 | 1,2 | 1,0 | | 36,0 |
| 38,0 | | | | | | | | | 0,9 | | | 38,0 |

Load charts • Traglasten • Capacités de levage Capacidades • Capacità • Таблицы грузоподъемности

Telescopic boom • Teleskopausleger • Flèche principale • Pluma telescópica
Braccio telescopico • Телескопическая стрела



11,0 - 51,0 m



7,2 m



360°



5,7 t



EN 13000

| m | 11,0 | 15,1 | 19,2 | 23,3 | 27,2 | 31,0 | 35,1 | 39,2 | 43,3 | 47,2 | 51,0 | m |
|------|------|------|------|------|------|------|------|------|------|------|------|------|
| 3,0 | 70,0 | 57,0 | 54,0 | | | | | | | | | 3,0 |
| 4,0 | 53,5 | 50,5 | 47,0 | 44,5 | | | | | | | | 4,0 |
| 5,0 | 44,0 | 44,0 | 42,0 | 39,0 | 35,5 | | | | | | | 5,0 |
| 6,0 | 36,0 | 36,5 | 36,5 | 33,0 | 31,5 | 27,0 | | | | | | 6,0 |
| 7,0 | 30,5 | 30,5 | 28,0 | 27,5 | 25,0 | 24,0 | 20,0 | | | | | 7,0 |
| 8,0 | 23,5 | 25,0 | 24,0 | 22,0 | 22,0 | 20,0 | 18,4 | 15,6 | | | | 8,0 |
| 9,0 | | 20,0 | 19,8 | 19,7 | 18,4 | 16,9 | 15,6 | 14,8 | 11,9 | | | 9,0 |
| 10,0 | | 16,6 | 17,0 | 16,8 | 15,8 | 14,4 | 14,0 | 12,7 | 11,9 | 9,2 | 7,5 | 10,0 |
| 11,0 | | 13,9 | 14,9 | 14,6 | 13,7 | 12,9 | 12,7 | 11,2 | 10,8 | 9,2 | 7,5 | 11,0 |
| 12,0 | | 12,0 | 12,7 | 12,8 | 12,0 | 12,1 | 11,2 | 10,7 | 9,9 | 9,2 | 7,5 | 12,0 |
| 13,0 | | 6,5 | 11,0 | 11,1 | 10,6 | 10,8 | 9,9 | 9,8 | 9,4 | 8,9 | 7,5 | 13,0 |
| 14,0 | | | 9,6 | 9,7 | 9,5 | 9,7 | 8,8 | 8,8 | 8,7 | 8,2 | 7,5 | 14,0 |
| 15,0 | | | 8,4 | 8,6 | 8,4 | 8,7 | 7,9 | 8,2 | 7,9 | 7,4 | 6,8 | 15,0 |
| 16,0 | | | 7,4 | 7,9 | 7,4 | 7,9 | 7,3 | 7,6 | 7,2 | 6,7 | 6,1 | 16,0 |
| 18,0 | | | | 6,5 | 5,9 | 6,3 | 6,5 | 6,3 | 5,9 | 5,5 | 5,0 | 18,0 |
| 20,0 | | | | 5,3 | 4,7 | 5,5 | 5,4 | 5,3 | 5,0 | 4,6 | 4,1 | 20,0 |
| 22,0 | | | | | 4,3 | 4,6 | 4,5 | 4,4 | 4,2 | 3,8 | 3,4 | 22,0 |
| 24,0 | | | | | 3,8 | 3,9 | 3,8 | 3,7 | 3,5 | 3,2 | 2,7 | 24,0 |
| 26,0 | | | | | | 3,3 | 3,2 | 3,1 | 2,9 | 2,6 | 2,2 | 26,0 |
| 28,0 | | | | | | 2,8 | 2,7 | 2,6 | 2,4 | 2,2 | 1,8 | 28,0 |
| 30,0 | | | | | | | 2,2 | 2,1 | 2,0 | 1,8 | 1,4 | 30,0 |
| 32,0 | | | | | | | 1,9 | 1,8 | 1,6 | 1,4 | 1,1 | 32,0 |
| 34,0 | | | | | | | | 1,5 | 1,3 | 1,1 | | 34,0 |
| 36,0 | | | | | | | | 0,9 | 1,0 | 0,8 | | 36,0 |



11,0 - 51,0 m



7,2 m



360°



4,5 t



EN 13000

| m | 11,0 | 15,1 | 19,2 | 23,3 | 27,2 | 31,0 | 35,1 | 39,2 | 43,3 | 47,2 | 51,0 | m |
|------|------|------|------|------|------|------|------|------|------|------|------|------|
| 3,0 | 70,0 | 57,0 | 54,0 | | | | | | | | | 3,0 |
| 4,0 | 53,5 | 50,5 | 47,0 | 44,5 | | | | | | | | 4,0 |
| 5,0 | 43,5 | 43,5 | 42,0 | 39,0 | 35,5 | | | | | | | 5,0 |
| 6,0 | 35,5 | 36,0 | 34,5 | 31,0 | 29,5 | 27,0 | | | | | | 6,0 |
| 7,0 | 29,0 | 29,0 | 26,5 | 26,0 | 25,0 | 23,0 | 20,0 | | | | | 7,0 |
| 8,0 | 22,0 | 23,5 | 22,5 | 22,0 | 20,5 | 18,9 | 17,4 | 15,6 | | | | 8,0 |
| 9,0 | | 19,0 | 18,7 | 18,6 | 17,4 | 15,9 | 14,6 | 13,9 | 11,9 | | | 9,0 |
| 10,0 | | 15,6 | 16,6 | 15,9 | 14,9 | 13,6 | 13,7 | 11,9 | 11,6 | 9,2 | 7,5 | 10,0 |
| 11,0 | | 13,3 | 14,1 | 13,8 | 12,9 | 12,9 | 11,9 | 11,2 | 10,3 | 9,2 | 7,5 | 11,0 |
| 12,0 | | 11,3 | 12,0 | 12,1 | 11,3 | 11,4 | 10,5 | 10,3 | 9,9 | 8,9 | 7,5 | 12,0 |
| 13,0 | | 6,5 | 10,3 | 10,5 | 10,0 | 10,2 | 9,3 | 9,2 | 9,1 | 8,5 | 7,5 | 13,0 |
| 14,0 | | | 9,0 | 9,1 | 8,9 | 9,1 | 8,3 | 8,6 | 8,2 | 7,7 | 7,0 | 14,0 |
| 15,0 | | | 7,9 | 8,4 | 7,8 | 8,2 | 7,7 | 7,9 | 7,4 | 6,9 | 6,3 | 15,0 |
| 16,0 | | | 6,9 | 7,5 | 6,9 | 7,4 | 7,3 | 7,1 | 6,7 | 6,2 | 5,7 | 16,0 |
| 18,0 | | | | 6,0 | 5,5 | 6,0 | 6,2 | 5,9 | 5,5 | 5,1 | 4,6 | 18,0 |
| 20,0 | | | | 4,9 | 4,7 | 5,2 | 5,1 | 4,9 | 4,6 | 4,2 | 3,7 | 20,0 |
| 22,0 | | | | | 4,2 | 4,3 | 4,2 | 4,1 | 3,8 | 3,5 | 3,0 | 22,0 |
| 24,0 | | | | | 3,5 | 3,6 | 3,5 | 3,4 | 3,2 | 2,9 | 2,4 | 24,0 |
| 26,0 | | | | | | 3,0 | 2,9 | 2,8 | 2,6 | 2,3 | 1,9 | 26,0 |
| 28,0 | | | | | | 2,5 | 2,4 | 2,3 | 2,1 | 1,9 | 1,5 | 28,0 |
| 30,0 | | | | | | | 2,0 | 1,9 | 1,7 | 1,5 | 1,1 | 30,0 |
| 32,0 | | | | | | | 1,7 | 1,6 | 1,4 | 1,2 | 0,8 | 32,0 |
| 34,0 | | | | | | | | 1,3 | 1,1 | 0,9 | | 34,0 |
| 36,0 | | | | | | | | | 0,8 | | | 36,0 |

Load charts • Traglasten • Capacités de levage Capacidades • Capacità • Таблицы грузоподъемности

Telescopic boom • Teleskopausleger • Flèche principale • Pluma telescópica
Braccio telescopico • Телескопическая стрела



11,0 - 51,0 m



7,2 m



360°



3,4 t



EN 13000

| m | 11,0 | 15,1 | 19,2 | 23,3 | 27,2 | 31,0 | 35,1 | 39,2 | 43,3 | 47,2 | 51,0 | m |
|------|------|------|------|------|------|------|------|------|------|------|------|------|
| 3,0 | 70,0 | 57,0 | 54,0 | | | | | | | | | 3,0 |
| 4,0 | 53,5 | 50,5 | 47,0 | 44,5 | | | | | | | | 4,0 |
| 5,0 | 43,0 | 43,0 | 42,0 | 39,0 | 35,5 | | | | | | | 5,0 |
| 6,0 | 36,5 | 35,5 | 33,0 | 29,5 | 28,0 | 27,0 | | | | | | 6,0 |
| 7,0 | 27,5 | 27,5 | 25,0 | 24,5 | 24,0 | 21,5 | 19,8 | | | | | 7,0 |
| 8,0 | 21,0 | 22,5 | 21,5 | 21,0 | 19,6 | 17,9 | 16,4 | 15,5 | | | | 8,0 |
| 9,0 | | 17,9 | 18,5 | 17,6 | 16,4 | 15,0 | 14,0 | 13,1 | 11,9 | | | 9,0 |
| 10,0 | | 14,9 | 15,7 | 15,0 | 14,1 | 13,6 | 12,9 | 11,7 | 10,9 | 9,2 | 7,5 | 10,0 |
| 11,0 | | 12,6 | 13,3 | 13,0 | 12,2 | 12,2 | 11,2 | 11,0 | 10,3 | 9,2 | 7,5 | 11,0 |
| 12,0 | | 10,6 | 11,3 | 11,4 | 10,6 | 10,8 | 9,8 | 9,7 | 9,6 | 8,9 | 7,5 | 12,0 |
| 13,0 | | 6,5 | 9,7 | 9,9 | 9,4 | 9,6 | 8,7 | 9,1 | 8,6 | 8,0 | 7,4 | 13,0 |
| 14,0 | | | 8,4 | 8,8 | 8,3 | 8,5 | 8,1 | 8,2 | 7,7 | 7,2 | 6,5 | 14,0 |
| 15,0 | | | 7,4 | 8,0 | 7,3 | 7,7 | 7,7 | 7,4 | 6,9 | 6,4 | 5,8 | 15,0 |
| 16,0 | | | 6,5 | 7,1 | 6,5 | 6,9 | 7,0 | 6,7 | 6,2 | 5,8 | 5,2 | 16,0 |
| 18,0 | | | | 5,6 | 5,3 | 5,9 | 5,8 | 5,5 | 5,1 | 4,7 | 4,2 | 18,0 |
| 20,0 | | | | 4,6 | 4,7 | 4,8 | 4,7 | 4,6 | 4,2 | 3,8 | 3,4 | 20,0 |
| 22,0 | | | | | 3,9 | 4,0 | 3,9 | 3,8 | 3,5 | 3,1 | 2,7 | 22,0 |
| 24,0 | | | | | 3,2 | 3,3 | 3,2 | 3,1 | 2,9 | 2,6 | 2,1 | 24,0 |
| 26,0 | | | | | | 2,7 | 2,6 | 2,5 | 2,4 | 2,1 | 1,7 | 26,0 |
| 28,0 | | | | | | 2,3 | 2,2 | 2,1 | 1,9 | 1,7 | 1,3 | 28,0 |
| 30,0 | | | | | | | 1,8 | 1,7 | 1,5 | 1,3 | 0,9 | 30,0 |
| 32,0 | | | | | | | 1,5 | 1,4 | 1,2 | 1,0 | | 32,0 |
| 34,0 | | | | | | | | 1,1 | 0,9 | | | 34,0 |
| 36,0 | | | | | | | | 0,8 | | | | 36,0 |



11,0 - 51,0 m



7,2 m



360°



0,5 t



EN 13000

| m | 11,0 | 15,1 | 19,2 | 23,3 | 27,2 | 31,0 | 35,1 | 39,2 | 43,3 | 47,2 | 51,0 | m |
|------|------|------|------|------|------|------|------|------|------|------|------|------|
| 3,0 | 70,0 | 57,0 | 54,0 | | | | | | | | | 3,0 |
| 4,0 | 52,5 | 50,5 | 47,0 | 44,5 | | | | | | | | 4,0 |
| 5,0 | 41,5 | 42,0 | 39,5 | 34,5 | 32,0 | | | | | | | 5,0 |
| 6,0 | 32,5 | 31,0 | 28,0 | 27,0 | 25,0 | 23,5 | | | | | | 6,0 |
| 7,0 | 23,5 | 24,0 | 23,0 | 22,5 | 20,5 | 18,5 | 16,8 | | | | | 7,0 |
| 8,0 | 17,7 | 19,1 | 19,1 | 18,1 | 16,7 | 15,1 | 14,0 | 13,0 | | | | 8,0 |
| 9,0 | | 15,6 | 15,8 | 15,0 | 14,0 | 13,9 | 12,7 | 12,3 | 10,9 | | | 9,0 |
| 10,0 | | 12,7 | 13,3 | 12,7 | 11,9 | 11,9 | 10,8 | 10,9 | 10,4 | 8,9 | 7,5 | 10,0 |
| 11,0 | | 10,5 | 11,3 | 11,0 | 10,2 | 10,3 | 9,9 | 9,8 | 9,1 | 8,5 | 7,5 | 11,0 |
| 12,0 | | 8,8 | 9,5 | 9,9 | 8,8 | 9,0 | 9,1 | 8,6 | 8,0 | 7,4 | 6,8 | 12,0 |
| 13,0 | | 6,5 | 8,1 | 8,7 | 7,7 | 8,0 | 8,0 | 7,6 | 7,1 | 6,6 | 6,0 | 13,0 |
| 14,0 | | | 7,0 | 7,6 | 6,8 | 7,5 | 7,2 | 6,8 | 6,3 | 5,8 | 5,2 | 14,0 |
| 15,0 | | | 6,1 | 6,6 | 6,4 | 6,8 | 6,4 | 6,1 | 5,6 | 5,2 | 4,6 | 15,0 |
| 16,0 | | | 5,3 | 5,9 | 6,0 | 6,1 | 5,8 | 5,4 | 5,0 | 4,6 | 4,1 | 16,0 |
| 18,0 | | | | 4,6 | 4,7 | 4,9 | 4,7 | 4,4 | 4,1 | 3,7 | 3,2 | 18,0 |
| 20,0 | | | | 3,7 | 3,8 | 3,9 | 3,8 | 3,6 | 3,3 | 2,9 | 2,5 | 20,0 |
| 22,0 | | | | | 3,0 | 3,2 | 3,1 | 3,0 | 2,6 | 2,3 | 1,9 | 22,0 |
| 24,0 | | | | | 2,4 | 2,6 | 2,5 | 2,4 | 2,1 | 1,8 | 1,4 | 24,0 |
| 26,0 | | | | | | 2,1 | 2,0 | 1,9 | 1,7 | 1,4 | 1,0 | 26,0 |
| 28,0 | | | | | | 1,7 | 1,6 | 1,5 | 1,3 | 1,0 | | 28,0 |
| 30,0 | | | | | | | 1,2 | 1,1 | 0,9 | | | 30,0 |
| 32,0 | | | | | | | 0,9 | 0,8 | | | | 32,0 |

Working range • Arbeitsbereiche • Diagramme de levage
 Gama de trabajo • Area di lavoro • Грузовысотные характеристики

Swingaway (hydraulic luffing) • Klappspitze (hydraulisch wippbar) • Extension treillis (déport hydraulique)
 Plumín (angulable hidráulicamente) • Falcone (brandeggio idraulico)
 Складной удлинитель стрелы (гидравлическое изменение вылета)



11,3 - 51,0 m



0°-40°
8,7/15,0/21,0 m



7,2 m



360°

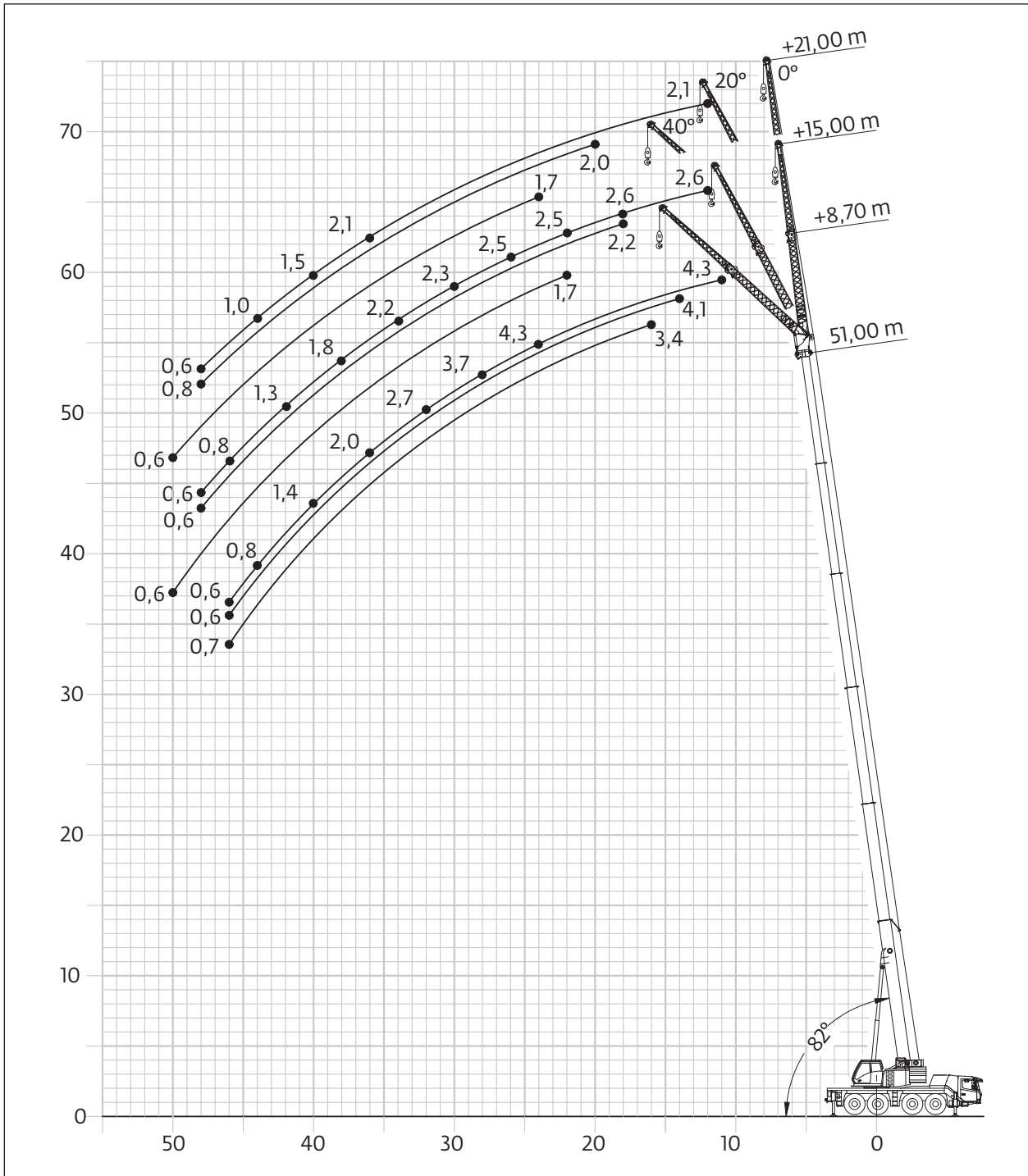

Working range • Arbeitsbereiche • Diagramme de levage Gama de trabajo • Area di lavoro • Грузовысотные характеристики

Swingaway (hydraulic luffing) • Klappspitze (hydraulisch wippbar) • Extension treillis (déport hydraulique)
lumin (angulable hidráulicamente) • Falcone (brandeggio idraulico)
Складной удлинитель стрелы (гидравлическое изменение вылета)



11,3 - 51,0 m



8,7 m



7,2 m



360°



14,8 t



EN 13000

| m | 11,0 | | | 31,0 | | | 47,21 | | | 51,0 | | | m |
|------|------|--------|---------|------|--------|---------|-------|--------|---------|------|--------|---------|------|
| | 0° | 0°-20° | 20°-40° | 0° | 0°-20° | 20°-40° | 0° | 0°-20° | 20°-40° | 0° | 0°-20° | 20°-40° | |
| 3,0 | 10,0 | | | | | | | | | | | | 3,0 |
| 4,0 | 8,9 | | | | | | | | | | | | 4,0 |
| 5,0 | 7,9 | 5,5 | | | | | | | | | | | 5,0 |
| 6,0 | 7,0 | 5,1 | | 8,6 | | | | | | | | | 6,0 |
| 7,0 | 6,3 | 4,7 | 3,9 | 8,5 | | | | | | | | | 7,0 |
| 8,0 | 5,8 | 4,4 | 3,7 | 8,3 | | | | | | | | | 8,0 |
| 9,0 | 5,3 | 4,2 | 3,6 | 8,0 | 5,1 | | | | | | | | 9,0 |
| 10,0 | 4,8 | 3,9 | 3,5 | 7,5 | 4,9 | | 5,2 | | | | | | 10,0 |
| 11,0 | 4,5 | 3,8 | 3,4 | 7,2 | 4,7 | 3,8 | 5,2 | | | 4,3 | | | 11,0 |
| 12,0 | 4,2 | 3,6 | 3,3 | 6,8 | 4,6 | 3,7 | 5,2 | | | 4,3 | | | 12,0 |
| 13,0 | 3,9 | 3,5 | 3,3 | 6,5 | 4,4 | 3,6 | 5,2 | 4,4 | | 4,3 | | | 13,0 |
| 14,0 | 3,7 | 3,3 | 3,3 | 6,2 | 4,3 | 3,6 | 5,2 | 4,3 | | 4,3 | 4,1 | | 14,0 |
| 15,0 | 3,5 | 3,3 | | 5,9 | 4,2 | 3,5 | 5,1 | 4,3 | 3,5 | 4,3 | 4,1 | | 15,0 |
| 16,0 | 3,3 | 3,2 | | 5,7 | 4,1 | 3,5 | 5,1 | 4,2 | 3,5 | 4,3 | 4,0 | 3,4 | 16,0 |
| 18,0 | | | | 5,2 | 3,9 | 3,4 | 5,1 | 4,0 | 3,4 | 4,3 | 3,9 | 3,4 | 18,0 |
| 20,0 | | | | 4,8 | 3,8 | 3,3 | 5,1 | 3,9 | 3,4 | 4,3 | 3,8 | 3,3 | 20,0 |
| 22,0 | | | | 4,5 | 3,6 | 3,3 | 4,9 | 3,8 | 3,3 | 4,3 | 3,7 | 3,3 | 22,0 |
| 24,0 | | | | 4,2 | 3,5 | 3,2 | 4,6 | 3,7 | 3,3 | 4,3 | 3,6 | 3,2 | 24,0 |
| 26,0 | | | | 4,0 | 3,4 | 3,2 | 4,2 | 3,6 | 3,2 | 4,2 | 3,5 | 3,2 | 26,0 |
| 28,0 | | | | 3,7 | 3,3 | 3,2 | 3,6 | 3,5 | 3,2 | 3,7 | 3,4 | 3,2 | 28,0 |
| 30,0 | | | | 3,5 | 3,2 | 3,2 | 3,1 | 3,1 | 3,2 | 3,2 | 3,2 | 3,1 | 30,0 |
| 32,0 | | | | 3,0 | 3,0 | | 2,6 | 2,6 | 2,8 | 2,7 | 2,7 | 2,9 | 32,0 |
| 34,0 | | | | 2,6 | 2,6 | | 2,2 | 2,2 | 2,4 | 2,3 | 2,3 | 2,5 | 34,0 |
| 36,0 | | | | 2,2 | 2,2 | | 1,8 | 1,8 | 2,0 | 2,0 | 2,0 | 2,1 | 36,0 |
| 38,0 | | | | | | | 1,5 | 1,5 | 1,6 | 1,6 | 1,6 | 1,8 | 38,0 |
| 40,0 | | | | | | | 1,2 | 1,2 | 1,3 | 1,4 | 1,4 | 1,5 | 40,0 |
| 42,0 | | | | | | | 0,9 | 0,9 | 1,1 | 1,1 | 1,1 | 1,2 | 42,0 |
| 44,0 | | | | | | | 0,7 | 0,7 | 0,8 | 0,8 | 0,8 | 1,0 | 44,0 |
| 46,0 | | | | | | | | | | 0,6 | 0,6 | 0,7 | 46,0 |

Working range • Arbeitsbereiche • Diagramme de levage Gama de trabajo • Area di lavoro • Грузовысотные характеристики

Swingaway (hydraulic luffing) • Klappspitze (hydraulisch wippbar) • Extension treillis (déport hydraulique)
Plumín (angulable hidráulicamente) • Falcone (brandeggio idraulico)
Складной удлинитель стрелы (гидравлическое изменение вылета)



11,3 - 51,0 m



15,0 m



7,2 m



360°



14,8 t



EN 13000

| m | 11,0 | | | 31,0 | | | 47,21 | | | 51,0 | | | m |
|------|------|----------------|---------|------|----------------|---------|-------|----------------|---------|------|----------------|---------|------|
| | 0° | 15,0 0°-20° | 20°-40° | 0° | 15,0 0°-20° | 20°-40° | 0° | 15,0 0°-20° | 20°-40° | 0° | 15,0 0°-20° | 20°-40° | |
| 3,0 | 5,0 | | | | | | | | | | | | 3,0 |
| 4,0 | 5,0 | | | | | | | | | | | | 4,0 |
| 5,0 | 5,0 | | | | | | | | | | | | 5,0 |
| 6,0 | 4,6 | | | | | | | | | | | | 6,0 |
| 7,0 | 4,1 | | | 4,5 | | | | | | | | | 7,0 |
| 8,0 | 3,8 | 2,8 | | 4,4 | | | | | | | | | 8,0 |
| 9,0 | 3,5 | 2,7 | | 4,4 | | | | | | | | | 9,0 |
| 10,0 | 3,2 | 2,5 | | 4,3 | | | | | | | | | 10,0 |
| 11,0 | 3,0 | 2,4 | | 4,2 | | | 3,0 | | | | | | 11,0 |
| 12,0 | 2,8 | 2,3 | 1,9 | 4,0 | | | 3,0 | | | 2,6 | | | 12,0 |
| 13,0 | 2,6 | 2,2 | 1,9 | 3,8 | 2,6 | | 3,0 | | | 2,6 | | | 13,0 |
| 14,0 | 2,5 | 2,1 | 1,8 | 3,6 | 2,5 | | 3,0 | | | 2,6 | | | 14,0 |
| 15,0 | 2,3 | 2,0 | 1,8 | 3,5 | 2,4 | | 2,9 | | | 2,6 | | | 15,0 |
| 16,0 | 2,2 | 1,9 | 1,7 | 3,3 | 2,3 | 1,9 | 2,9 | | | 2,6 | | | 16,0 |
| 18,0 | 2,0 | 1,8 | 1,6 | 3,1 | 2,2 | 1,8 | 2,9 | 2,3 | | 2,6 | 2,2 | | 18,0 |
| 20,0 | 1,8 | 1,6 | 1,6 | 2,8 | 2,1 | 1,8 | 2,9 | 2,2 | 1,8 | 2,5 | 2,2 | | 20,0 |
| 22,0 | 1,6 | 1,6 | | 2,6 | 2,0 | 1,7 | 2,8 | 2,1 | 1,8 | 2,5 | 2,1 | 1,7 | 22,0 |
| 24,0 | 1,5 | 1,6 | | 2,5 | 1,9 | 1,7 | 2,7 | 2,1 | 1,7 | 2,5 | 2,0 | 1,7 | 24,0 |
| 26,0 | | | | 2,3 | 1,9 | 1,6 | 2,6 | 2,0 | 1,7 | 2,5 | 2,0 | 1,7 | 26,0 |
| 28,0 | | | | 2,2 | 1,8 | 1,6 | 2,5 | 1,9 | 1,7 | 2,4 | 1,9 | 1,7 | 28,0 |
| 30,0 | | | | 2,1 | 1,7 | 1,6 | 2,4 | 1,9 | 1,6 | 2,3 | 1,9 | 1,6 | 30,0 |
| 32,0 | | | | 1,9 | 1,7 | 1,6 | 2,3 | 1,8 | 1,6 | 2,2 | 1,8 | 1,6 | 32,0 |
| 34,0 | | | | 1,9 | 1,6 | 1,6 | 2,2 | 1,8 | 1,6 | 2,2 | 1,8 | 1,6 | 34,0 |
| 36,0 | | | | 1,8 | 1,6 | 1,6 | 2,1 | 1,7 | 1,6 | 2,1 | 1,7 | 1,6 | 36,0 |
| 38,0 | | | | 1,7 | 1,6 | 1,6 | 1,8 | 1,7 | 1,6 | 1,8 | 1,7 | 1,6 | 38,0 |
| 40,0 | | | | 1,6 | 1,5 | | 1,5 | 1,5 | 1,6 | 1,6 | 1,6 | 1,6 | 40,0 |
| 42,0 | | | | 1,6 | 1,5 | | 1,2 | 1,2 | 1,5 | 1,3 | 1,3 | 1,5 | 42,0 |
| 44,0 | | | | | | | 1,0 | 1,0 | 1,2 | 1,1 | 1,1 | 1,3 | 44,0 |
| 46,0 | | | | | | | 0,7 | 0,7 | 0,9 | 0,8 | 0,8 | 1,1 | 46,0 |
| 48,0 | | | | | | | | | 0,7 | 0,6 | 0,6 | 0,8 | 48,0 |
| 50,0 | | | | | | | | | | | | 0,6 | 50,0 |

Working range • Arbeitsbereiche • Diagramme de levage Gama de trabajo • Area di lavoro • Грузовысотные характеристики

Swingaway (hydraulic luffing) • Klappspitze (hydraulisch wippbar) • Extension treillis (déport hydraulique)
Plumín (angulable hidráulicamente) • Falcone (brandeggio idraulico)
Складной удлинитель стрелы (гидравлическое изменение вылета)



11,3 - 51,0 m



21,0 m



7,2 m



360°



14,8 t



EN 13000

| m | 11,0 21,0 | | | 31,0 21,0 | | | 47,21 21,0 | | | 51,0 21,0 | | | m |
|------|--------------|--------|---------|--------------|--------|---------|---------------|--------|---------|--------------|--------|---------|------|
| | 0° | 0°-20° | 20°-40° | 0° | 0°-20° | 20°-40° | 0° | 0°-20° | 20°-40° | 0° | 0°-20° | 20°-40° | |
| 4,0 | 5,0 | | | | | | | | | | | | 4,0 |
| 5,0 | 5,0 | | | | | | | | | | | | 5,0 |
| 6,0 | 4,9 | | | | | | | | | | | | 6,0 |
| 7,0 | 4,6 | | | | | | | | | | | | 7,0 |
| 8,0 | 4,3 | | | 3,8 | | | | | | | | | 8,0 |
| 9,0 | 4,0 | 2,8 | | 3,8 | | | | | | | | | 9,0 |
| 10,0 | 3,7 | 2,7 | | 3,8 | | | | | | | | | 10,0 |
| 11,0 | 3,5 | 2,6 | | 3,7 | | | 2,5 | | | | | | 11,0 |
| 12,0 | 3,3 | 2,4 | 2,0 | 3,7 | | | 2,5 | | | 2,1 | | | 12,0 |
| 13,0 | 3,1 | 2,4 | 1,9 | 3,7 | | | 2,5 | | | 2,1 | | | 13,0 |
| 14,0 | 2,9 | 2,3 | 1,9 | 3,6 | 2,5 | | 2,5 | | | 2,1 | | | 14,0 |
| 15,0 | 2,7 | 2,2 | 1,8 | 3,5 | 2,4 | | 2,5 | | | 2,1 | | | 15,0 |
| 16,0 | 2,6 | 2,1 | 1,8 | 3,4 | 2,4 | | 2,5 | | | 2,1 | | | 16,0 |
| 18,0 | 2,4 | 2,0 | 1,7 | 3,2 | 2,3 | 1,8 | 2,4 | 2,3 | | 2,1 | | | 18,0 |
| 20,0 | 2,2 | 1,8 | 1,7 | 3,0 | 2,2 | 1,8 | 2,4 | 2,2 | | 2,1 | 2,0 | | 20,0 |
| 22,0 | 2,0 | 1,7 | 1,6 | 2,8 | 2,1 | 1,7 | 2,4 | 2,1 | 1,8 | 2,1 | 2,0 | | 22,0 |
| 24,0 | 1,8 | 1,7 | 1,6 | 2,6 | 2,0 | 1,7 | 2,4 | 2,0 | 1,7 | 2,1 | 2,0 | 1,7 | 24,0 |
| 26,0 | 1,7 | 1,6 | 1,6 | 2,5 | 1,9 | 1,7 | 2,4 | 2,0 | 1,7 | 2,1 | 1,9 | 1,7 | 26,0 |
| 28,0 | 1,6 | 1,6 | | 2,3 | 1,9 | 1,6 | 2,4 | 1,9 | 1,7 | 2,1 | 1,9 | 1,6 | 28,0 |
| 30,0 | 1,5 | 1,6 | | 2,2 | 1,8 | 1,6 | 2,4 | 1,9 | 1,6 | 2,1 | 1,8 | 1,6 | 30,0 |
| 32,0 | | | | 2,1 | 1,7 | 1,6 | 2,3 | 1,8 | 1,6 | 2,1 | 1,8 | 1,6 | 32,0 |
| 34,0 | | | | 2,0 | 1,7 | 1,6 | 2,2 | 1,8 | 1,6 | 2,1 | 1,8 | 1,6 | 34,0 |
| 36,0 | | | | 1,9 | 1,7 | 1,6 | 2,0 | 1,7 | 1,6 | 2,1 | 1,7 | 1,6 | 36,0 |
| 38,0 | | | | 1,8 | 1,6 | 1,6 | 1,7 | 1,7 | 1,6 | 1,8 | 1,7 | 1,6 | 38,0 |
| 40,0 | | | | 1,8 | 1,6 | 1,6 | 1,4 | 1,4 | 1,6 | 1,5 | 1,5 | 1,5 | 40,0 |
| 42,0 | | | | 1,7 | 1,6 | 1,6 | 1,2 | 1,2 | 1,5 | 1,2 | 1,2 | 1,5 | 42,0 |
| 44,0 | | | | 1,5 | 1,5 | | 1,0 | 1,0 | 1,2 | 1,0 | 1,0 | 1,3 | 44,0 |
| 46,0 | | | | 1,3 | 1,3 | | 0,7 | 0,7 | 1,0 | 0,8 | 0,8 | 1,0 | 46,0 |
| 48,0 | | | | 1,1 | 1,1 | | | | 0,8 | 0,6 | 0,6 | 0,8 | 48,0 |
| 50,0 | | | | | | | | | | | | 0,6 | 50,0 |

Specifications

Superstructure



Boom

11,0 m to 51,0 m six section TWIN-LOCK® boom.
Maximum tip height 54,0 m.



Boom elevation

1 cylinder with safety valve, boom angle from -3,0° to +82°.



Load moment and independent anti-two block system

Load moment and independent anti-two block system with audio visual warning and control lever lock-out. These systems provide graphic display of boom angle, length, radius, tip height, relative load moment, maximum permissible load, load indication and warning of impending two-block condition with lock-out hoist function.



Cab

Aluminium, full vision, tiltable (approx. 20°), safety glass, adjustable operator's seat with suspension (optional), engine-independent heater. Armrest integrated crane controls. Ergonomically arranged instrumentation and crane operating controls.



Slewing

2 slewing gears with axial piston motors, planetary gears, automatic break.



Counterweight

14,8 tonnes, consisting of various sections (14,8 t within 2,55 m vehicle width). Hydraulic removal system.



Hydraulic system

2 separate circuits, 1 axial piston variable displacement pump with electronic power limiting control and 1 axial piston variable displacement pump for slewing.

Thermostatically controlled oil cooler. Tank capacity: 450 l.



Control system

Full electronic control of all crane movements using electrical control levers with automatic reset to zero. Integrated with the RCL and engine management system by CAN-BUS. Crane Control System (CCS) with graphic display.



Hoist

Axial piston motor with planetary gear and brake. Drum rotation indicator.

* Optional equipment

- Bi-fold swingaway, 8,7/15 m with hydraulic offset and luffing under load (0°-40°), controlled from the crane cab.
- Bi-fold swingaway, 8,7/15 m (manual offset 0°, 20°, 40°).
- Lattice extension, 21 m - includes 6m fixed non-offsettable section plus 8,7/15 m swingaway (see above).
- Auxiliary hoist.

Carrier



Chassis

Special 4-axle chassis, all-welded torsion-resistant box type construction in high strength steel.



Outriggers

4 double hydraulically telescoping beams with vertical cylinders and outrigger pads. Independent horizontal and vertical movement control on each side of the carrier and from the operators cab. Electronic level indicator with automatic levelling system.



Engine

Mercedes Benz OM470LA, diesel, 6 cylinders, water cooled, turbocharged, 320 kW at 1700 rpm (80/1269 EWG fan loose).

Max. torque: 2100 Nm at 1300 rpm. Fuel tank: 200 l + 200 l.

Engine emission: Euromot 5 / EPA / CARB Tier 4 final (non road) - optional Euromot 3a / EPA / CARB Tier 3 (non road).



Transmission

Mercedes G 280-16 gears forward and 2 reverse. 2-stage transfer case with longitudinal differential lock.



Drive/Steer

8 x 6 x 8.



Axle lines

4 axle lines, axle lines 1, 2, 3 and 4 steered, axle line 1, 3 and 4 driven.



Suspension

MEGATRAK®. All wheels with independent hydropneumatic suspension and hydraulic lockout. Longitudinal and transverse level control with automatic on highway levelling system. Range +170 mm/-126 mm. Active suspension control on outrigger control units.



Tyres

8 tyres, 385/95 R25 (14.00 R25).



Steering

Dual circuit, hydraulic power assisted steering with emergency steering pump. Axle lines 1, 2 and 4 steer on highway. Separate electronic hydraulic (steer by wire) steering of the 3rd, and 4th axle line for all wheel steering and crabbing.



Brakes

Service brake: pneumatic dual circuit drum brakes acting on all wheels, air dryer. Permanent brake: exhaust brake and constant throttle brake.

Parking brake: pneumatically operated spring-loaded brake acting on axle lines 2, 3 and 4.



Driver's Cab

2-man design, safety glass, driver seat with pneumatic suspension, engine-independent diesel air heater incl. 24 h timer. Complete instrumentation and driving controls. Air condition. 12 V plug. Two rotating beacons. Fire extinguisher.



Electrical system

Three-phase alternator 28 V/150 A, 2 batteries 12 V/180 Ah. Lighting system and signals 24 V.

* Optional equipment

- Drive/steer: 8 x 8 x 8
- 8 tyres, size 445/95 R25 (16.00 R25) - Vehicle width 2,75 m.
- 8 tyres, size 525/80 R25 (20.5 R25) - Vehicle width 2,88 m.
- Folding bunk bed in carrier cab.
- Secondary water retarder.
- Reverse camera system.

*Further optional equipment on request.

Kranoberwagen



Teleskopausleger

11,0 m bis 51,0 m sechsteiliger TWIN-LOCK® Ausleger.
Maximale Rollenkopfhöhe 54,0 m.



Wippwerk

1 Zylinder mit Sicherheits-Rückschlagventil.
Auslegerverstellwinkel -3,0° bis +82°.



Elektronischer Lastmomentbegrenzer und unabhängiges Hubendschalter System

Elektronischer Lastmomentbegrenzer mit hör- und sichtbarer Vorwarnung sowie automatischer Abschaltung, Digitalanzeige für Auslegerwinkel, Länge, Radius, Rollenhöhe, relatives Lastmoment, zulässige Belastung und unabhängiges Hubendschalter-System mit Abschaltfunktion.



Krankabine

Vollsicht-Aluminium-Kabine, ca. 20° kippbar, Sicherheitsglas, verstellbarer Fahrersitz mit Dämpfung (optional), motorunabhängige Heizung. In Armlehnen integrierte Kransteuereinrichtung. Ergonomisch angeordnete Steuer- und Kontrolleinrichtungen.



Drehwerk

2 Drehwerke mit Axialkolbenmotoren, Planetengetriebe, Automatikbremse.



Gegengewicht

14,8 Tonnen, bestehend aus mehreren Teilen (14,8 t innerhalb der Fahrzeugbreite von 2,55 m). Hydraulisches Rüstsystem.



Hydrauliksystem

2 separate Kreisläufe, 1 Axialkolben-Verstellpumpe mit elektronischer Grenzlastregelung und Axialkolben-Verstellpumpe für das Drehwerk. Thermostatisch gesteuerter Ölkühler. Tankvolumen: 450 l.



Steuerung

Vollelektronische Steuerung sämtlicher Bewegungen mit elektrischen Steuerhebeln mit automatischer Nullstellung. Verbunden mit dem RCL und dem Motormanagement System über einen CAN-BUS. Intuitives Kransteuersystem (CCS) mit grafischer Anzeige.



Hubwerk

Achskolbenmotoren mit Planetengetriebe und Bremse. Hubwerksdrehmelder.

* Zusatzausrüstung

- Doppelklappspitze 8,7/15 m. Abwinkelung (0°- 40°). Aus der Kranfahrerkabine hydraulisch einstellbar und unter Teillast wippbar.
- Doppelklappspitze 8,7/15 m (0°, 20°, 40° manuell abwinkelbar).
- Auslegerverlängerung, Gitterkonstruktion 21 m, bestehend aus 8,7/15 m Doppelklappspitze (siehe oben) und einem 6 m Verlängerungsstück.
- Hilfshubwerk.

Kranunterwagen



Rahmen

4-Achs-Spezialfahrzeug, geschweißte, torsionssteife Kastenkonstruktion aus hochfestem Feinkornstahl.



Abstützung

4 doppelt hydraulisch teleskopierbare Schiebeträger mit Abstützylindern und Abstützplatten, beidseitig vom Unterwagen aus einzeln horizontal und vertikal und von der Krankabine aus steuerbar. Elektronische Niveauanzeige mit automatischer Nivellierung.



Motor

Mercedes Benz OM470LA, 6 Zylinder Diesel, wassergekühlt, mit Turbolader, 320 kW bei 1700 U/Min. (80/1269/EWG Ventilator lose). Max. Drehmoment: 2100 Nm bei 1300 U/Min.

Kraftstoffbehälter: 200 l + 200 l.

Motoremission: Euromot 5 / EPA / CARB Tier 4 final (non road) - optional Euromot 3a / EPA / CARB Tier 3 (non road).



Getriebe

Mercedes G 280-16 Gänge vorwärts und 2 Gänge rückwärts. Verteilergetriebe 2 stufig mit Längsdifferentialsperre.



Antrieb/Lenkung

8 x 6 x 8.



Achslinien

4 Achslinien, Achslinien 1, 2, 3 und 4 gelenkt; Achslinien 1, 3 und 4 angetrieben.



Federung

MEGATRAK®. Alle Räder in Einzelaufhängung, hydropneumatische Federung und hydraulische Blockierung. Neigungsverstellung in Längs- und Querrichtung mit automatischer Straßenfahrniveaueinstellung. Federweg +170 mm/-126 mm. Aktive Federung. Steuerung auf der Abstützungssteuerung.



Bereifung

8 Reifen, Größe 385/95 R25 (14.00 R25).



Lenkung

Zweikreis-Hydraulenklung mit Notlenkpumpe. Während der Straßenfahrt werden die 1., 2. und 4. Achse gelenkt. Separate elektrohydraulische (Steer-by-wire) Lenkung der 3. und 4. Achse für Allradlenkung und Hundegang.



Bremsen

Betriebsbremse: Pneumatische Zweikreis-Trommelbremsen auf alle Räder wirkend, Lufttrockner.

Dauerbremse: Motorklappenbremse mit Konstantdrossel.

Feststellbremse: druckluftbetätigte Federspeicherbremse auf die Achslinien 2, 3 und 4 wirkend.



Fahrerhaus

2-Mann-Fahrerhaus, Sicherheitsglas, luftgedämpfter Fahrersitz, motorunabhängige Dieselluftheizung mit integrierter 24h-Zeitschaltuhr. Klimaanlage. 12V Stecker. Zwei Rundum-Blinkleuchten. Feuerlöscher.



Elektrische Anlage

Drehstromlichtmaschine 28 V/150 A, 2 Batterien 12 V/180 Ah, Beleuchtungsanlage und 24 V Signale.

* Zusatzausrüstung

- Antrieb/Lenkung: 8 x 8 x 8.
- 8 Reifen, Größe 445/95 R25 (16.00 R25) - Fahrzeugbreite 2,75 m.
- 8 Reifen, Größe 525/80 R25 (20.5 R25) - Fahrzeugbreite 2,88 m.
- Klappolie im Fahrerhaus.
- Sekundär-Wasserretarder.
- Rückfahrkamera.

*Weitere Zusatzausrüstungen auf Anfrage.

Caractéristiques techniques

Superstructure



Flèche

Flèche TWIN-LOCK® de 11,0 m à 51,0 m en six sections. Hauteur maximum de tête de flèche 54,0 m.



Relevage

1 vérin avec soupape de sécurité, angle de relevage de -3,0° à +82°.



Contrôleur d'état de charge et dispositif de fin de course haute crochet indépendant

Contrôleur d'état de charge et dispositif de fin de course haute crochet indépendant avec alarme sonore et visuelle et coupure des mouvements. Ces systèmes fournissent un affichage graphique de l'angle de flèche, de la longueur, du rayon, de la hauteur de tête de flèche, du moment de charge relatif, de la charge maximum autorisée, de l'état de charge et d'approche de fin de course haute crochet avec coupure du mouvement de montée de treuil.



Cabine

Cabine Aluminium, panoramique, inclinable (environ 20°), verre de sécurité, siège utilisateur réglable à suspension (optionnels), chauffage autonome. Manipulateurs de commandes de grue intégrés aux accoudoirs. Disposition ergonomique de l'instrumentation et des commandes.



Orientation

2 dispositifs d'orientation avec moteurs à pistons axiaux, engrenages planétaires, frein automatique.



Contrepoids

14,8 tonnes, constitué de différentes sections (14,8 t sur une largeur de véhicule de 2,55 m). Système de dépose hydraulique.



Système hydraulique

2 circuits indépendants, 1 pompe à pistons axiaux et débit variable avec dispositif de régulation de puissance électronique et 1 pompe à pistons axiaux et débit variable pour l'orientation. Refroidisseur d'huile à commande thermostatique. Capacité du réservoir: 450 l.



Commande

Commande entièrement électronique de l'ensemble des mouvements de la grue avec manipulateurs électriques avec retour au neutre automatique. Intégrée au contrôleur d'état de charge et au dispositif de gestion du moteur par système CAN-BUS. Système de commande de la grue (CCS) avec affichage graphique.



Treuil de levage

Moteur à pistons axiaux avec engrenage planétaire et frein. Indicateur de rotation de tambour.

* Equipements optionnels

- Extension treillis à repliage latéral double de 8,7/15 m – avec déport hydraulique et inclinaison sous charge (0°-40°) commandés depuis la cabine.
- Extension treillis à repliage latéral double de 8,7/15 m (inclinable à 0°, 20°, 40°).
- Extension treillis de 21 m constituée de : extension treillis double (voir ci-dessus) plus éléments intermédiaires de 6 m.
- Treuil auxiliaire.

Porteur



Châssis

Châssis 4 essieux spécial, construction de type caisson résistant à la torsion entièrement soudée en acier haute résistance.



Calage

4 poutres à double télescopage hydraulique avec vérins verticaux et patins de stabilisation. Commande indépendante des mouvements horizontaux et verticaux des deux côtés du porteur et depuis la cabine de conduite. Indicateur de niveau électronique avec système de mise à niveau automatique.



Moteur

Mercedes Benz OM470LA, diesel, 6 cylindres, refroidissement liquide, turbo, 320 kW à 1700 trs/min (80/1269/CEE - ventilateur débrayé). Couple maxi: 2100 Nm à 1300 trs/min. Réservoir de carburant: 200 l + 200 l. Emissions du moteur: Euromot 5 / EPA / CARB Tier 4 final (tout terrain) - optionnel Euromot 3a / EPA / CARB Tier 3 (tout terrain).



Boîte de vitesses

Mercedes G 280-16 rapports de marche avant et 2 rapports de marche arrière. Boîte de transfert à 2 étages verrouillage longitudinal différentiel.



Direction/Transmission

8 x 6 x 8.



Lignes d'essieux

4 lignes d'essieu, lignes d'essieu 1, 2, 3 et 4 directrices, lignes d'essieu 1, 3 et 4 motrices.



Suspension

MEGATRAK®. Toutes les roues sont équipées de dispositifs de suspension hydropneumatiques indépendants et de verrouillages hydrauliques. Commande de mise à niveau longitudinal et transversal avec système de mise à niveau en position route. Débattement +170 mm/-126 mm. Contrôle de suspension actif sur les unités de commande de stabilisation.



Pneumatiques

8 pneumatiques 385/95 R25 (14.00 R25).



Direction

Direction assistée à puissance hydraulique à double circuit et pompe de secours. Lignes d'essieu 1, 2 et 4 directionnelles sur route. Direction hydraulique électronique indépendante (direction par câble) des lignes d'essieu 3 et 4 pour direction toutes roues et déplacement latéral (marche en crabe).



Freins

Frein de service : freins pneumatiques à double circuit agissant sur toutes les roues, dessiccateur. Frein permanent : frein sur échappement et frein à étranglement constant. Frein de stationnement : frein à ressort à commande pneumatique agissant sur les lignes d'essieu 2, 3 et 4.



Cabine

2 places, verre de sécurité, siège de conducteur à suspension pneumatique, chauffage de l'air diesel indépendant du moteur incluant une minuterie de 24 h. Instruments complets et commandes de pilotage. Air conditionné. Prise 12 V. Deux balises rotatives. Extincteur.



Installation électrique

Alternateur triphasé 28 V/150 A, 2 batteries 12 V/180 Ah. Equipement d'éclairage et de signalisation 24 V.

* Equipements optionnels

- Direction/transmission: 8 x 8 x 8.
- 8 pneumatiques, taille 445/95 R25 (16.00 R25) – Largeur de véhicule 2,75 m.
- 8 pneumatiques, taille 525/80 R25 (20.5 R25) – Largeur de véhicule 2,88 m.
- Banquette repliable dans la cabine porteur.
- Ralentisseur à eau secondaire.
- Système de caméra de recul.

* Autres équipements optionnels sur demande.

Superestructura



Pluma

Pluma TWIN-LOCK® de seis secciones de 11,0 m to 51,0 m. Altura máxima en punta de 54,0 m.



Elevación de pluma

Un cilindro con válvula de seguridad, ángulo de pluma de -3,0° a +82°.



Sistema Indicador del Momento de Carga y de Final de Carrera del Gancho

Sistema indicador del momento de carga y del final de carrera del gancho con alarma auditiva y visual y bloqueo de las palancas. Estos sistemas incluyen pantalla gráfica con indicación del ángulo de la pluma, longitud, radio, altura en punta, momento de carga relativo, carga máxima permisible, indicación de carga y alarma de final de carrera del gancho con bloqueo del movimiento de elevación.



Cabina

De Aluminio, con visión completa, basculable (aprox. 20°), cristal de seguridad, asiento del operador ajustable con suspensión (opcional), calefacción independiente del motor. Controles de la grúa integrados en el reposabrazos. Instrumentos y controles de funcionamiento de la grúa dispuestos de forma ergonómica.



Giros

2 coronas de giro con motores de pistones axiales, engranajes planetarios, freno automático.



Contrapeso

14,8 toneladas, compuesto de varios bloques (14,8 t en 2,55 m de ancho del vehículo). Sistema de desmontaje hidráulico.



Sistema hidráulico

2 circuitos separados, una bomba de desplazamiento variable de pistones axiales con control electrónico de limitación de potencia y bomba de desplazamiento variable de pistones axiales para rotación. Refrigerador de aceite controlado con termostato. Capacidad del depósito: 450 l.



Sistema de control

Control electrónico completo de todos los movimientos de la grúa usando palancas de control eléctrico con retorno automático a cero. Integrado en el limitador de capacidad nominal y el sistema de gestión del motor con un dispositivo CAN-BUS. Sistema de control de grúa con pantalla gráfica.



Cabrestante

Motor de pistones axiales con engranaje planetario y freno. Indicador de rotación del tambor.

* Equipos opcionales

- Plumín articulado en 2 secciones, 8,7/15 m - con angulación fija y variable, con carga (0° - 40°) de accionamiento hidráulico.
- Plumín articulado en 2 secciones, 8,7/15 m (angulable 0°, 20°, 40°).
- Extensión de pluma, de celosía de 21 m, incluyendo el plumín de 8,7/15 m (el de arriba) más extensiones de 6m.
- Cabrestante Auxiliar.

Chasis



Armazón

Armazón especial de 4 ejes, de fabricación soldada de tipo cajón, resistente a la torsión, de acero de alta resistencia.



Estabilizadores

4 vigas dobles telescópicas hidráulicas con cilindros verticales y placas de apoyo. Control independiente de los movimientos horizontales y verticales en cada lado del chasis y desde la cabina del operador. Indicador electrónico de nivel con sistema de nivelación automática.



Motor

Mercedes Benz OM470LA, diésel, 6 cilindros, refrigerado con agua, turboalimentado, 320 kW a 1700 rpm (80/1269 CEE ventilador desconectado). Par máximo: 2100 Nm a 1300 rpm. Depósito de combustible: 200 l + 200 l. Emisión de gases del motor: Euromot 5 / EPA / CARB Tier 4 Final (fuera de carretera) - opcional Euromot 3a / EPA / CARB Tier 3 (fuera de carretera).



Transmisión

Mercedes G 280-16 velocidades adelante y 2 atrás. Caja transferencia de 2 velocidades con bloqueo diferencial longitudinal.



Tracción/Dirección

8 x 6 x 8.



Líneas de ejes

4 líneas de ejes, líneas de ejes 1, 2, 3 y 4 directrices, líneas de ejes 1, 3 y 4 motrices.



Suspensión

MEGATRAK®. Todas las ruedas cuentan con suspensión hidroneumática independiente y bloqueo hidráulico. Control de nivel longitudinal y transversal con sistema de nivelación automática en carretera. Desplazamiento +170 mm/-126 mm. Control de suspensión activo en las unidades de control de los estabilizadores.



Neumáticos

8 neumáticos, 385/95 R25 (14.00 R25).



Dirección

Dirección servoasistida con doble circuito con bomba de dirección de emergencia. Líneas de ejes 1, 2 y 4 son directrices para circular por carretera. Dirección separada electrónica hidráulica (dirección por cable) de las líneas de ejes 3 y 4 para la dirección en todas las ruedas y el desplazamiento lateral.



Frenos

Freno de servicio: frenos de tambor neumáticos con doble circuito con acción en todas las ruedas, secador de aire. Freno continuo: freno sobre el escape y con estrangulamiento continuo. Freno de estacionamiento: freno accionado neumáticamente y aplicado por muelle en las líneas de ejes 2, 3 y 4.



Cabina del conductor

Diseño para 2 personas, cristal de seguridad, asiento del conductor con suspensión neumática, calefacción diésel de aire independiente del motor con temporizador de 24 h. Instrumentos y controles de conducción completos. Aire acondicionado. Conector de 12 V. Dos faros giratorios. Extintor.



Sistema eléctrico

Alternador trifásico de 28 V/150 A, 2 baterías de 12 V/180 Ah. Sistema de alumbrado y señalización de 24 V.

* Equipos opcionales

- Tracción/dirección: 8 x 8 x 8.
- 8 neumáticos 445/95 R25 (16.00 R25) - Anchura del vehículo de 2,75 m.
- 8 neumáticos, tamaño 525/80 R25 (20.5 R25) - Anchura del vehículo de 2,88 m.
- Litera plegable en la cabina del chasis.
- Ralentizador de agua secundario.
- Sistema de cámara de marcha atrás.

* Sigüientes equipos bajo demanda.

Caratteristiche

Torretta



Braccio

Braccio TWIN-LOCK® da 11,0 m a 51,0 m composto da sei sezioni. Altezza massima della punta 54,0 m.



Sollevamento Braccio

1 cilindro con valvola di sicurezza, angolo del braccio da -3,0° a +82°.



Limitatore di carico e blocco dei movimenti

Limitatore del momento di carico e dispositivo di finecorsa indipendente con allarme visivo e sonoro e blocco della leva di comando. Questi sistemi sono provvisti di display grafico che indica l'angolo e la lunghezza del braccio, il raggio, l'altezza della punta, il momento di carico relativo, il carico massimo ammissibile, l'indicazione del carico e l'avviso di imminente condizione di finecorsa con funzione di blocco dell'argano.



Cabina

Costruita in alluminio, grande visibilità, indinabile (circa 20°), cristalli di sicurezza, sedile dell'operatore regolabile con sospensione (opzionali), riscaldamento indipendente dal motore. Comandi della gru integrati nei braccioli. Disposizione ergonomica della strumentazione e dei comandi di funzionamento della gru.



Rotazione

2 motoriduttori di rotazione a pistoni assiali, riduttore planetario e freno automatico.



Zavorra

14,8 tonnellate, in più sezioni (14,8 t all'interno della larghezza del veicolo di 2,55 m). Sistema di rimozione idraulico.



Impianto idraulico

2 circuiti separati, 1 pompa a pistoni assiali a portata variabile con limitatore elettronico e pompa a pistoni assiali a portata variabile per la rotazione. Raffreddamento dell'olio con controllo termostatico. Capacità del serbatoio: 450 l.



Comandi

Controllo completamente elettronico di tutti i movimenti della gru con leve di comando a controllo elettronico con azzeramento automatico. Integrato con il sistema RCL e il sistema CAN-BUS di controllo del motore. Crane Control System (CCS, Sistema di comando della gru) con sistema con display grafico.



Argano

Motore a pistoni assiali con riduttore planetario e freno. Indicatore della rotazione del tamburo.

* Accessori opzionali

- Prolunga tralicciata pieghevole 8,7/15 m, inclinabile idraulicamente sotto carico (0°-40°), controllata dalla cabina gru.
- Falcone ripiegabile da 8,7/15 m inclinabile a 0°, 20°, 40°.
- Prolunga tralicciata 21 m inclusi 6 metri fissi non angolabili, più prolunga tralicciata 8,7/15 m (vedi sopra).
- Argano ausiliario.

Carro



Telaio

Telaio speciale a 4 assi, completamente saldato, in acciaio scatorato ad alta resistenza, resistente alla torsione.



Stabilizzatori

4 doppie travi orizzontali telescopiche idrauliche con cilindri verticali e piatti di stabilizzazione. Controllo dei movimenti orizzontale e verticale indipendente su ogni lato del carro e dalla cabina dell'operatore. Indicatore elettronico di livello con sistema automatico di livellamento.



Motore

Mercedes Benz OM470LA, diesel, a 6 cilindri, raffreddato ad acqua, turbo-compresso, 320 kW a 1700 giri al minuto (80/1269 CEE ventola disinnescata). Coppia max.: 2100 Nm a 1300 giri al minuto. Serbatoio di carburante: 200 l + 200 l. Emissione del motore: Euromot 5 / EPA / CARB Tier 4 final (non su strada) - opzionale Euromot 3a / EPA / CARB Tier 3 (non su strada).



Cambio

Mercedes G 280 con 16 marce avanti e 2 retromarce. Gruppo di rinvio a 2 velocità con blocco del differenziale longitudinale.



Trazione/Sterzo

8 x 6 x 8.



Assali

4 assali, assale 1, 2, 3 e 4 sterzanti, assale 1, 3 e 4 di trazione.



Sospensioni

MEGATRAK®. Tutte le ruote hanno sospensioni idropneumatiche indipendenti e blocco idraulico. Controllo del livellamento longitudinale e trasversale con livellamento automatico per la circolazione stradale. Corsa +170 mm/-126 mm. Controllo delle sospensioni attive sulle unità di controllo degli stabilizzatori.



Pneumatici

8 pneumatici, 385/95 R25 (14.00 R25).



Sterzo

Doppio circuito servoassistito idraulicamente con pompa di sterzata di emergenza. Assali 1, 2 e 4 comandati dallo sterzo durante la marcia. Sterzo separato a comando elettronico-idraulico (steer by wire) per il 3° e 4° assale per eseguire la sterzata combinata e a granchio.



Freni

Freno di servizio: freni a tamburo pneumatici a doppio circuito agenti su tutte le ruote, con essiccatore dell'aria. Freno continuo: freno motore e valvola di decompressione costante. Freno di stazionamento: con molle precaricate a comando pneumatico agenti sugli assali 2, 3 e 4.



Cabina dell'autista

A 2 posti, con cristalli di sicurezza, sedile dell'autista con sospensione pneumatica, riscaldatore dell'aria a gasolio indipendente dal motore con timer 24 h. Completa strumentazione e comandi di guida. Aria condizionata. Presa 12 V. Due lampeggianti rotanti. Estintore.



Impianto elettrico

Alternatore trifase 28 V/150A, 2 batterie 12 V/180 Ah.

* Accessori opzionali

- Trazione/sterzo: 8 x 8 x 8.
- 8 pneumatici, misura 445/95 R25 (16.00 R25) - Larghezza veicolo 2,75 m.
- 8 pneumatici, misura 525/80 R25 (20.5 R25) - Larghezza veicolo 2,88 m.
- Cuccetta ribaltabile nella cabina del carro.
- Retarder secondario ad acqua.
- Telecamera di retromarcia.

* Altri a richiesta.

Крановая установка



Стрела

Шестисекционная стрела TWIN-LOCK* 11,0 - 51,0 м. Максимальная высота оголовка стрелы 54,0 м.



Подъем стрелы

1 цилиндр с предохранительным клапаном, угол подъема от -3,0° до +82°.



Ограничитель грузового момента и независимая система блокировки при подъеме

Ограничитель грузового момента и независимая система блокировки при подъеме со звуковой и визуальной сигнализацией и блокировкой органов управления. Эти системы выводят на дисплей угол наклона стрелы, длину, радиус, высоту оголовка стрелы, относительный грузовой момент, максимально допустимую нагрузку, текущую нагрузку и предупреждение о возможности перегруза, который повлечет за собой блокировку управления краном.



Кабина

Алюминиевая, с круговым обзором, наклоняемая (примерно 20°), бесколочное стекло, регулируемое место оператора с подвеской (опция), устройство для обогрева от двигателя. Органы управления краном встроены в подлокотник. Эргономичная приборная панель и система управления краном.



Поворот

2 поворотных механизма с аксиально-поршневыми моторами, планетарной передачей и автоматическим тормозом.



Противовес

14,8 т, состоит из различных секций (14,8 т при ширине тягача 2,55 м). Гидравлическая система демонтажа противовесов.



Гидравлическая система

2 отдельных контура, 1 аксиально-поршневой нагнетательный насос с электронным ограничителем мощности и 1 аксиально-поршневой нагнетательный насос для поворота крана. Охлаждитель масла, регулируемый с помощью термореле. Емкость бака: 450 л.



Система управления

Полностью электронная система управления движением крана с электрорычагами управления и автоматическим возвратом в нейтральное положение. Эта система соединена с ограничителем номинальной мощности и системой управления работой двигателя при помощи шины CAN-BUS. Система управления краном (CCS) с графическим дисплеем.



Грузовая лебедка (основная)

Аксиально-поршневой мотор с планетарной передачей и тормозом. Индикатор вращения барабана.

* Дополнительное оборудование (по выбору)

- Складной удлинитель стрелы 8,7/15 м, с гидравлическим регулированием вылета и возможностью управления под нагрузкой (0° - 40°), управляемый из кабины оператора.
- Двусторонний складной удлинитель стрелы 8,7/15 м (регулирование вручную 0°, 20°, 40°).
- Удлинитель стрелы, 21 м - включает 5 промежуточные вставки и 8,7/15 м Складной удлинитель стрелы (см. выше).
- Лебедка вспомогательного подъема.

Тягач



Шасси

Специальное 4-осное шасси, цельносварной раме, к с повышенной жесткостью на кручение, коробчатого типа, из высокопрочной стали.



Выносные опоры

4 двухступенчатые балки с гидравлическим телескопированием с вертикальными цилиндрами и основаниями выносных опор. Независимые пульты управления горизонтального и вертикального перемещения, расположенные по сторонам тягача и в кабине оператора. Электронный индикатор уровня с автоматической системой выравнивания.



Двигатель

Mercedes Benz OM470LA, дизельный, 6-цилиндровый, с водяным охлаждением, с турбонаддувом, 320 кВт при 1700 об/мин (80/1269 EWG - сменный вентилятор). Максимальный крутящий момент: 2100 Н·м при 1300 об/мин. Топливный бак: 200 л + 200 л. Выбросы двигателя: Euromot 5 / EPA / CARB Tier 4 final / Евро 6 (вне дорожный) - по выбору Euromot 3a / EPA / CARB Tier 3 (вне дорожный).



Коробка передач

Mercedes G 280 – 16 передач переднего и 2 передачи заднего хода. Двухступенчатая раздаточная коробка с механизмом блокировки межосевых дифференциалов.



Ведущие/Управляемые оси

8 x 6 x 8.



Оси

4 оси: оси 1, 2, 3, 4 – управляемые, оси 1, 3, 4 – приводные.



Подвеска

MEGATRAK*. Полностью независимая гидропневматическая с гидравлической блокировкой. Контроль продольного и поперечного уровня с автоматической системой выравнивания на дороге. Диапазон регулировки +170 мм/-126 мм. Активное управление подвеской на пультах управления выносных опор.



Шины

8 шин, 385/95 R25 (14.00 R25).



Рулевое управление

Двухконтурный гидравлический усилитель рулевого управления с аварийным насосом. Оси 1, 2, 4 для управления при езде по дорогам общего пользования. Раздельное электронное гидравлическое (проводное) управление осями 3 и 4 для обеспечения криволинейного хода и движения по пересеченной местности.



Тормоза

Рабочая тормозная система: пневматическая двухконтурная; барабанные тормоза, для всех колес, осушитель воздуха. Вспомогательный тормоз: приспособление для дросселирования выхлопа моторный тормоз. Стояночный тормоз: пневматически управляемый пружинный тормоз на осях 2, 3, 4.



Кабина водителя

Двухместная, остекление из травмобезопасного бесколочного стекла, сиденье водителя с пневматической подвеской, независимый от двигателя дизельный подогреватель с 24-часовым таймером. эргономичная панель контрольно-измерительных приборов и органов управления. Кондиционер. Розетка 12 В. Два вращающихся проблесковых маячка. Огнетушитель.



Электрическая система

Трехфазный генератор переменного тока 28 В/150 А, 2 батареи 12 В/180 А·ч. Система освещения и сигнализации 24 В.

* Дополнительное оборудование (опции)

- Ведущие/Управляемые оси: 8 x 8 x 8.
- 8 шин, размер 445/95 R25 (16.00 R25) при ширине тягача 2,75 м.
- 8 шин, размер 525/80 R25 (20.5 R25) при ширине тягача 2,88 м.
- Складное спальное место в кабине тягача.
- Замедлитель технической воды.
- Система камер для движения задним ходом.

* Прочее дополнительное оборудование предоставляется по запросу.

Load charts • Traglasten • Capacities de levage Capacidades • Tabelle di portata • Таблицы грузоподъемности

The lifting capacities correspond to EN 13000:2010-10.

The lifting capacities likewise fulfil the requirements of ISO 4305 with regard to stability.

The lifting capacities are given in tonnes.

Lifting capacity = Payload + weight of hook block and suspending device.

The lifting capacities for the main boom only apply with the jib dismantled.

Lifting capacities > 59 t require additional equipment.

Lifting capacities > 75 t require special equipment.

The right is reserved to modify the load-carrying capacities.

Note: The details in this brochure serve only as general information. The determinant values for the operation of the crane are the lifting capacity tables belonging to it and the operating instructions.

Lifting capacities are indicated by boom length for different levels of extension. The actual boom length will be in accordance with the selected configuration for boom extension.

Die Tragfähigkeiten entsprechen EN 13000:2010-10.

Die Tragfähigkeitswerte erfüllen ebenfalls die Anforderungen von ISO 4305 bezüglich Standsicherheit.

Die Tragfähigkeitswerte sind in Tonnen angegeben.

Tragfähigkeit = Nutzlast + Gewicht der Hakenflasche und Anschlagmittel.

Die Tragfähigkeitswerte für den Hauptausleger gelten nur bei demontierten Spitzenauslegern.

Die Tragfähigkeitswerte > 59 t erfordern eine Zusatzausrüstung.

Die Tragfähigkeitswerte > 75 t erfordern eine Sonderausrüstung.

Änderung der Tragfähigkeiten vorbehalten.

Anmerkung: Die Daten dieser Broschüre dienen nur zur allgemeinen Information. Maßgebend für den Betrieb des Kranes sind die zugehörigen Tragfähigkeitstabellen und die Bedienungsanleitung.

Die Traglastwerte sind aus unterschiedlichen Teleskopierungen pro Auslegerlänge zusammengefasst. Die tatsächliche Auslegerlänge kann variieren.

Les capacités de levage sont conformes à la norme EN 13000:2010-10.

Les capacités de levage respectent également les exigences des normes ISO 4305 relatives à la stabilité.

Les capacités de levage sont exprimées en tonnes.

Capacité = charge utile + poids du crochet et du dispositif d'élingage.

Les capacités de levage de la flèche principale ne sont valables que lorsque la fléchette est démontée.

Des capacités de levage >59 tonnes exigent l'utilisation d'un dispositif supplémentaire.

Des capacités de levage >75 tonnes exigent l'utilisation d'un dispositif spécial.

Le constructeur se réserve le droit d'apporter des modifications à ces capacités de levage.

Remarque : Les données de cette brochure ne sont fournies qu'à titre d'information générale. La manipulation de la grue nécessite l'étude des tableaux de capacité et la lecture des guides d'utilisation correspondants.

Les capacités de levage sont données par longueur de flèche pour différents niveaux de télescopage. Les longueurs de flèche réelles peuvent varier.

Las capacidades de carga corresponden a EN 13000:2010-10.

Asimismo los valores de carga cumplen las disposiciones de las normas ISO 4305 respecto a la estabilidad.

Los valores de carga se dan en toneladas.

Capacidad de carga = Carga + peso de la garrucha del gancho y del mecanismo de elevación.

Los valores de carga para la pluma principal sólo son válidos cuando no hay plumines instalados.

Valores de carga > 59 t requieren un mecanismo de elevación suplementario.

Valores de carga > 75 t requieren una unidad especial.

Se reserva el derecho a modificar las capacidades de carga.

Nota: Los detalles contenidos en este folleto sirven sólo como información general. Los valores determinantes para el funcionamiento de la grúa son los cuadros de cargas correspondientes, así como las instrucciones de funcionamiento.

Las capacidades de carga se indican por longitud de pluma para los diferentes niveles de despliegue. Las longitudes reales de la pluma pueden variar.

Le tabelle di portata sono conformi alle norme EN 13000:2010-10.

I valori delle tabelle di portata sono conformi anche ai requisiti delle norme ISO 4305 per quanto riguarda la stabilità.

I valori di portata sono indicati in tonnellate.

Capacità di portata = carico utile + peso del gancio e accessori di sollevamento.

I valori delle tabelle di portata per il braccio principale si applicano solo con le punte bracci smontate.

Valori di portata > 59 t richiedono un'attrezzatura supplementare.

Valori di portata > 75 t richiedono un'unità speciale.

Si riserva il diritto di modificare i valori di portata.

Nota: i dettagli forniti nel presente opuscolo servono solo come informazioni di carattere generale. I valori determinanti per il funzionamento della gru sono le tabelle di portata appartenenti alla gru stessa e le istruzioni di funzionamento.

Le capacità di sollevamento sono relative alla lunghezza del braccio con differenti configurazioni di telescopaggio. Le lunghezze reali del braccio possono variare.

Грузоподъемность соответствует EN 13000:2010-10.

Кроме того, грузоподъемность удовлетворяет требованиям ISO 4305 в отношении устойчивости.

Грузоподъемность приведена в тоннах.

Грузоподъемность = Полезный груз + вес крюкового блока и устройства для подвешивания.

Грузоподъемность основной стрелы только при сложенном удлинителе.

Грузоподъемность > 59 т необходимо дополнительное оборудование.

Грузоподъемность > 75 т необходимо специальное оборудование.

Оставляем за собой право изменять грузоподъемность.

Примечание: В данной брошюре приведена только общая информация. Рабочие значения для крана приведены в таблицах грузоподъемности (см. данную брошюру и инструкции по эксплуатации).

Грузоподъемность приведена по длине стрелы для различных уровней телескопирования. Действительная длина стрелы может варьироваться.

Symbols • Symbolerklärung • Glossaire des symboles Glosario de simbolos • Glossario dei simboli • Символы

| | | | | | | | |
|---|--|---|---|---|---|---|---|
|  | Axles Achsen Ponts Ejes Assali Оси |  | Counterweight Gegengewicht Contrepoids Contrapeso Contrappeso Противовес |  | Main hoist Haupthubwerk Treuil principal Cabrestante principal Argano principale Лебедка основного подъема |  | Radius Ausladung Portée Radio Raggio Вылет |
|  | Axle load Achslast Charge à l'essieu Carga por eje Carico sugli assi Нагрузка на ось |  | Crane functions Kranbewegungen Mouvements de la grue Funciones de la grúa Funzioni della gru Функции крана |  | Auxiliary hoist Hilfshubwerk Treuil auxiliaire Cabrestante auxiliar Argano secondario Лебедка вспомогательного подъема |  | Slewing/Working range Drehwerk/Arbeitsbereich Orientation/Rayon d'opération Giro/Gama de trabajo Rotazione/Area di lavoro Поворот/Рабочий диапазон |
|  | Boom Ausleger Flèche Pluma Braccio Стрела |  | Crane travel Fahrstellung Déplacement de la grue Grúa en traslado Traslazione gru Перемещение крана |  | Hookblock/Capacity Hakenflasche/Traglast Moufle/Force de levage Gancho/Capacidad Gancio/Capacità Крюковой блок/ Грузоподъемность |  | Speed Geschwindigkeit Vitesse Velocidad Velocità Скорость |
|  | Boom elevation Wippwerk Relevage Elevación de pluma Elevazione braccio Подъем стрелы |  | Drive/Steer Antrieb/Lenkung Direction/Déplacement Tracción/Dirección Trazione/Sterzo Ведущие/Управляемые оси |  | Hydraulic system Hydrauliksystem Circuit hydraulique Sistema hidráulico Impianto idraulico Гидравлическая система |  | Suspension Federung Suspension Suspensión Sospensioni Подвеска |
|  | Boom telescoping Teleskopieren Télescopage de flèche Telescopaje de pluma Lunghezza braccio Выдвижение стрелы |  | Electrical system Elektrische Anlage Circuit électrique Sistema eléctrico Impianto elettrico Электросистема |  | Lattice extension Gittermastspitze Extension treillis Extensión de celosía Falcone tralicciato Гусек |  | Transmission/Gear Getriebe/Gang Boîte de vitesses/Rapport Transmisión/Cambio Trasmiszione/Cambio Трансмиссия/передача |
|  | Brakes Bremsen Freins Frenos Freni Тормоза |  | Engine Motor Moteur Motor Motore Двигатель |  | Lattice extension (luffing) Gittermastspitze (wippbar) Extension treillis (volée variable) Extensión de celosía (angularmente) Falcone tralicciato (inclinabile) Гусек (с изменением вылета) |  | Travel speed Fahrgeschwindigkeit Vitesse de déplacement Velocidad de desplazamiento Velocità di traslazione Скорость движения |
|  | Cab Kabine Cabine Cabina Cabina Кабина |  | Free on wheels Freistehend Sur pneus Sobre neumáticos Su gomma Характеристика «на колесах» аутриггеры не развернуты |  | Luffing jib Wippspitze Volée variable Plumín angular Falcone a volata variabile Маневровый гусек |  | Tyres Bereifung Pneumatiques Neumáticos Pneumatici Шины |
|  | Carrier frame Chassis-Rahmen Châssis porteur Bastidor Telaio Рама тягача |  | Gradeability Steigfähigkeit Aptitude en pente Superación de pendientes Pendenza superabile Преодолеваемый уклон |  | Low range Kriechgang Gamme basse Marchas cortas Fuoristrada Низкий диапазон |  | Storage box + rigging gear Staukasten + Anschlagmittel Boîte de stockage + matériel de levage Caja de almacenamiento + cadenas, estrobo y eslingas Cassetta + attrezzi di sollevamento Ящик для хранения и такелажа |
|  | Hose reel Schlauchtrommel Enrouleur Bobina de manguera Avvolgitubo Барабан лебедки |  | Swingaway Klappspitze Extension Treillis Plumín Prolunga tralicciata Откидной удлинитель стрелы |  | Brackets Konsolen Supports Ménsula Staffe Кронштейны | | |
|  | Weight per axle in kg Gewicht je Achse in kg Poids par essieu en kg Peso por eje en kg Peso per assale in kg Нагрузка на ось в кг |  | Driveline Antriebsstrang Transmission Transmisión Trasmiszione Трансмиссия |  | Outriggers Abstützung Calage Estabilizadores Stabilizzatori Выносные опоры | | |

Manitowoc Cranes

Regional headquarters

Americas

Milwaukee, Wisconsin, USA

Tel: +1 414 760 4600

Shady Grove, Pennsylvania, USA

Tel: +1 717 597 8121

Europe and Africa

Dardilly, France - TOWERS

Tel: +33 (0)4 72 18 20 20

Wilhelmshaven, Germany - MOBILE

Tel: +49 (0) 4421 294 0

APAC

Shanghai, China

Tel: +86 21 6457 0066

Singapore

Tel: +65 6264 1188

Middle East and India

Dubai, UAE

Tel: +971 4 8862677



This document is non-contractual. Constant improvement and engineering progress make it necessary that we reserve the right to make specification, equipment, and price changes without notice. Illustrations shown may include optional equipment and accessories and may not include all standard equipment.

Die Angaben in diesem Dokument erfolgen ohne Gewähr. Wir verbessern unsere Produkte ständig und integrieren den technischen Fortschritt. Aus diesem Grund behalten wir uns das Recht vor, die technischen Daten, die Ausstattungsdetails und die Preise unserer Maschinen ohne Vorankündigung zu ändern.

Ce document est non-contractuel. Du fait de sa politique d'amélioration constante de ses produits liée au progrès technique, la Société se réserve le droit de procéder sans préavis à des changements de spécifications, d'équipement ou de prix. Les illustrations peuvent comporter des équipements ou accessoires optionnels ou ne pas comporter des équipements standards.

Este documento no es contractual. El perfeccionamiento constante y el avance tecnológico hacen necesario que la empresa se reserve el derecho de efectuar cambios en las especificaciones, equipo y precios sin previo aviso. En las ilustraciones se puede incluir equipo y accesorios opcionales y es posible que no se muestre el equipo normal.

Documento non contrattuale. In considerazione della sua politica di costante miglioramento dei prodotti connesso al progresso tecnico, la Società si riserva il diritto di modificare senza preavviso specifiche, equipaggiamenti o prezzi. Le illustrazioni possono contenere equipaggiamenti o accessori optional o non contenere equipaggiamenti standard.

Данный документ не является контрактным. Принимая во внимание необходимость постоянного совершенствования и модернизации мы оставляем за собой право изменять спецификации, конструкции и стоимость без предварительного уведомления. Приведенные иллюстрации могут содержать дополнительные компоненты и принадлежности, не входящие в стандартный комплект поставки оборудования.